

Owner's Manual



Axles, Brakes, Hubs and Drums
8,000 lbs. to 16,000 lbs.





Table of Contents

Introduction.....	4
Safety.....	5
Before The First Trip.....	6-7
General Maintenance.....	8-9
Weighing The Trailer.....	10
Storage Maintenance.....	11
Service Preparation.....	12
Brake Assemblies.....	13-20
Adjustment.....	13-14
Shoe & Lining.....	15-17
Magnet.....	18-20
Bearings, Races and Seals.....	21-22
Brake Drum/Rotor.....	23-25
Completing Service.....	26
Tire Inspection.....	27
Troubleshooting.....	28-31
Suspension Components.....	32-33
Replacement Parts.....	34-44
Asbestos and Non-Asbestos Fiber Warning.....	45
Wheel Mounting and Compatibility.....	46
Warranty.....	47
Service Record.....	48-51



Approved



Introduction

AL-KO Kober Corporation is a major supplier to the trailer industry. Our axles, brakes, hubs and drums are in operation around the world, helping trailers tow smoothly and stop safely. Our product line is the result of years of advanced engineering in the United States as well as Germany, where vehicular technology is unsurpassed. AL-KO products have undergone years of exhaustive testing and we continue to strive for superior reliability, safety and performance.

This manual contains information about axle assemblies, attaching parts, electric brakes, hydraulic drum brakes, hydraulic disc brakes and air brakes.

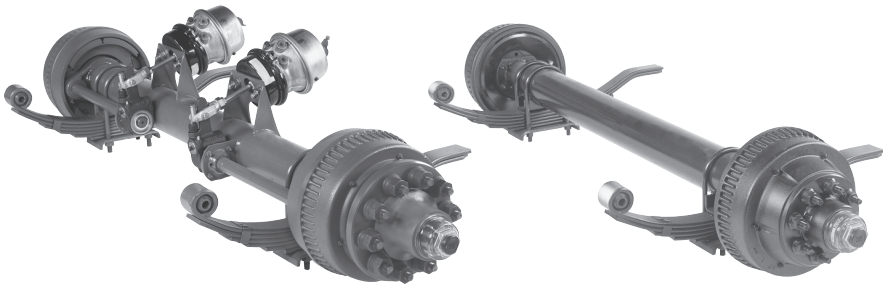

16K Air Brake (Axle Assembly)

10K General Duty (Axle Assembly)

Always use genuine AL-KO Kober replacement parts.

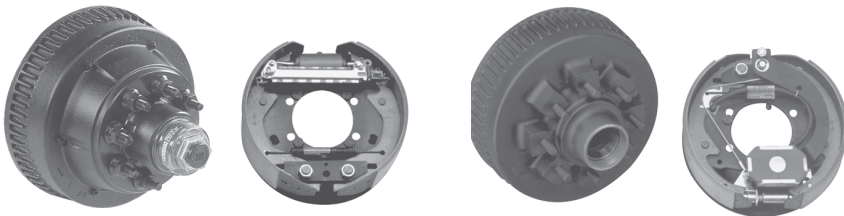

Hub/Drum and Hydraulic Brake

Hub/Drum and Electric Brake

Adhering to the recommended service schedule on pages 8-9 will ensure the finest towing and stopping action available.





Safety First

This manual describes service and repair procedures for AL-KO Kober trailer axles. Technicians must follow their employer's procedures and these procedures when servicing or repairing equipment or components. Before performing any service or maintenance, review the trailer manufacturer's recommendation for procedures and warnings.

The service and maintenance procedures are provided for use by qualified service technicians. Do not attempt to service, repair or work on brakes or axles unless you have appropriate mechanical knowledge and skills. You must understand all procedures and instructions before you begin to work on a unit. Some procedures require the use of special tools for safe and correct service. Failure to use special tools when required can cause damage to equipment and components. Lack of proper training, failure to follow proper procedures, or not using proper tools or safety equipment, can result in property damage, serious personal injury, or loss of life.

The following symbols are used to warn the user of potential dangers that could cause serious damage to equipment or cause personal injury or death.

 **WARNING** *This indicates a procedure that you must follow exactly to avoid damaging equipment or components and to avoid serious personal injury or loss of life.*

 **FASTENER TORQUE WARNING** *Fasteners must be tightened to a specific torque value. The technician must use the proper torque wrench to perform these operations. Improper torque can result in product failure which could cause property damage, serious injury, or loss of life.*

 **ASBESTOS FIBER WARNING** *Current AL-KO brake linings are asbestos free. Other brake linings may contain asbestos fibers, a cancer and lung disease hazard. Many brake linings contain non-asbestos fibers, whose long-term effects to health are unknown. You must use caution when you handle both asbestos and non-asbestos materials. (See page 45.)*

 **DANGER**
SAFETY GLASSES REQUIRED *To prevent serious eye injury, always wear safety eye protection when you perform vehicle maintenance or service.*



Before The First Trip

- ① **Adjust brakes:** Many of AL-KO Kober's heavy duty brakes are self adjusting. Depending on the conditions, some may need to be manually adjusted. Before the first trip, read the brake section that corresponds with your braking system - electric, hydraulic drum or hydraulic disc. Be sure to follow all procedures. A "green brake" is an unburnished brake. Normal manufacturing tolerances dictate that there is a break-in period required after which the lining will seat and become perfectly concentric with the drum. During this break-in period, the user must be aware that additional brake adjustments are mandatory to achieve optimum braking performance.

 **WARNING** *Failure to adjust brakes can result in brake lockup, reduced brake performance, or total loss of brakes which can lead to serious personal injury or loss of life.*

- ② **Set the hitch or pin height** of the tow vehicle so that the trailer is being pulled in a horizontal position. Trailers must be towed as level as possible. If the trailer leans down in the front it will distribute too much weight to the front axle. If the hitch or pin height is too high, the rear axle will receive too much of the load. Either condition can overload an axle even if the trailer is not overloaded.

 **WARNING** *Improper trailer position can cause tow vehicle handling problems resulting in property damage, serious personal injury, or loss of life.*

- ③ **Set wheel nut torque** as it may loosen several times before the wheel is properly seated to the wheel mounting surface. Wheel nut torque must be checked with a torque wrench and adjusted if necessary. Do not overtighten. Be sure to follow the instructions on page 26.

 **FASTENER TORQUE WARNING** *Torque wheel nuts now and then every fifty miles for the first 200 miles and then according to the schedule on page 8. Over-or under-torqued wheel nuts can cause the wheel to separate from the wheel mounting surface during operation. Wheel separation can result in property damage, serious personal injury, or loss of life. (See page 26 for torque specifications.)*

Before The First Trip

- ④ **Synchronize the trailer brakes** with the tow vehicle brakes. Trailer brakes are designed to stop the trailer. They cannot stop both the tow vehicle and trailer. Improper synchronization between the trailer and tow vehicle brakes can overload the brakes and generate excessive heat, causing brake fade or failure. Proper synchronization is achieved when the trailer's brakes have a slight lead over the tow vehicle's brakes. This is accomplished by adjusting the brake actuation mechanism. There are several types of Actuation Systems available depending on the type of brakes. These include Electric Brake Controller, Electric Over Hydraulic, Vacuum Over Hydraulic, Air Over Hydraulic and Straight Air. See the manufacturer's recommendation for adjusting the Actuation System. When done properly, there should be no sensation of the trailer "pushing" or "pulling" the tow vehicle.

 **WARNING** *Road test before using. Be sure area is clear of traffic and pedestrians. Do not exceed 30 m.p.h. Follow procedures outlined by the controller manufacturer. Failure to do so could result in property damage, serious personal injury, or loss of life.*

- ⑤ **Weigh the trailer** after it is fully loaded and ready for use. Axles, brakes, wheels, tires, frames and suspension components are designed to carry a specific maximum weight. Locate the VIN (Vehicle Identification Number) plate on the trailer. It will show the GVWR (Gross Vehicle Weight Rating). The GVWR is the total amount your trailer (including tongue weight) can weigh when it is completely loaded. The GAWR (Gross Axle Weight Rating) is the maximum load that the axles will carry and the maximum load the brakes will stop. Follow the instructions on page 10 for weighing the trailer and determining weight distribution.

 **WARNING** *Exceeding the GVWR (Gross Vehicle Weight Rating), the GAWR (Gross Axle Weight Rating), or having improper weight distribution can result in reduced performance or failure of the axle(s), brakes, and other suspension components. This failure can lead to property damage, serious personal injury, or loss of life.*

General Maintenance

To keep a trailer towing smoothly and stopping safely, it is recommended that service be done at the intervals below. *(Severe conditions, including excessive brake use, extremely rough roads, etc. may require more frequent maintenance.)*



WARNING

Improper or inadequate maintenance could result in premature wear or component failure which could result in property damage, serious personal injury, or loss of life.

Component	Check	Break-In Service		Standard Service Schedule				Reference
		Service During "Break In Period"	Daily	Weekly	3000 miles or 3 months whichever comes first	6000 miles or 6 months whichever comes first		
Trailer Brakes	Test for proper function.	Before First Trip	✓				See Actuation Manufacturer's Instructions	
Tires	Inflate to proper pressure. Check for abnormal wear.	Before First Trip	✓				Page 27	
Wheel	Inspect for damage, nicks, or out of round.	Every 50 Miles for First 200 Miles			✓		See Wheel Manufacturer's Instructions	
Wheel Nuts (Lug Nuts)	Tighten to proper torque specs.	Every 50 Miles for First 200 Miles	Repeat "Break-In Service whenever wheel is removed"		✓		Page 26	
Brake Adjustment	Test brake drag and adjust if required.	After First 200 Miles			✓		Page 13-14	
Brake Assembly	Check for adequate lubrication.	None				✓	Page 16	
Wheel Bearings	Repack bearings; inspect for wear or damage.	None				✓	Pages 21-22	
Hub/Drum/Rotor Assemblies	Check for heavy scoring or wear.	None				✓	Pages 23-25	

Seals	Inspect for damage or wear.	None				✓	Pages 21-22
Springs	Check for broken, separated or flattened springs.	Check After First 500 Miles				✓	Visual Inspection
Suspension Components	Check fastener torque and for worn or bent parts.	Visually Check After First 500 Miles				✓	Pages 32-33
Brake Linings/Pads	Inspect for excessive, unusual wear or contamination.	None				✓	Pages 15-17
Brake Plumbing/Wiring	Inspect for cracks, leaks, shorts, kinks, wear or breakage.	None				✓	
Check Oil Level	Should be to fill line in oil cap.	Before First Trip	✓				Page 22
Change Hub Oil	Visually check for contamination.	None					
Break-away Battery	Check for proper function. Inspect connections.	Before First Trip	✓				Measure Voltage
Break-away Switch	Check for proper function. Inspect connections.	Before First Trip	✓				See Manufacturer's Instructions
Brake Magnets	Inspect for uneven wear.	None				✓	Pages 18-20
Camshaft Bushings	Check for unusual wear.	None				✓	
Anchor Pins & Rollers	Check for wear.	None				✓	
Slack Adjuster Lubrication	Check lubrication.	None				✓	
Brake Cylinders/Calipers	Visually check for leaks & proper function.	None				✓	

12 months or 70,000 miles, whichever comes first.
(For severe conditions, 6 months or 30,000 miles)



Weighing The Trailer

Find a scale large enough to weigh the trailer. They are generally available at truck stops, concrete yards, grain elevators, etc.

- ① First, weigh the trailer in its entirety (including the tongue weight) while detached from the tow vehicle. This weight must be less than the GVWR (Gross Vehicle Weight Rating) on the VIN plate. If overweight, contents must be unloaded until it is within the GVWR limits.
- ② Attach the trailer to the tow vehicle. Weigh the total of all trailer wheels, making sure the tow vehicle is off of the scale. If this reading exceeds the GAWR, contents must be unloaded.

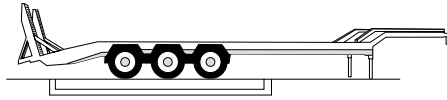

It is equally important that the load is distributed evenly among all of the axles and wheels. **One axle or wheel may be overloaded even if the GVWR and GAWR weights are within limits.**

- ③ Pull the trailer forward until the front axle is off of the scale. On tandem axle trailers, both axles should be carrying about the same load. If not, level the trailer or redistribute the load.

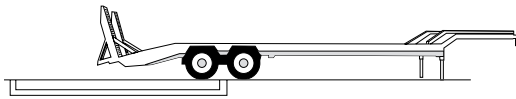

- ④ For triple axle trailers, pull the trailer forward again until the front two axles are off the scale. Calculate the weight of each axle and balance accordingly.

Also, check weight distribution at each wheel. Use the above technique weighing only the right or left side. Calculate the weight at each wheel.

Be sure that no one wheel is overloaded. If you have trouble calculating or interpreting the weights, contact your dealer or vehicle manufacturer.

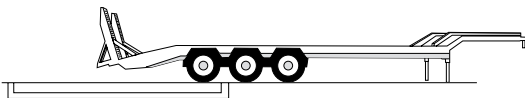



Storage Maintenance

Before Storing

- ① Disconnect the break-away battery and store indoors. Periodically check and recharge if necessary.
- ② Park trailer on a level area.
- ③ Lift trailer per instructions on page 12.
- ④ Place auxiliary blocking under the frame so that all weight is removed from the wheels.

 **WARNING** *See manufacturer's recommendation for position of blocks. Never use the axle or any portion of the suspension to lift or support the trailer. This will damage the axle and lead to premature failure which could result in property damage, serious personal injury, or loss of life.*

- ⑤ Lubricate the moving suspension parts. (See page 32.)
If axles have been exposed to immersion or excessive moisture, check hub/drum and bearings for moisture and change oil as necessary. (See pages 21-22.)
- ⑥ Oil will settle in the hub/drum. Rotate the wheel every one to two weeks to redistribute oil.

After Storage (Two Months or Longer)

- ① Follow instructions on page 12 for "Service Preparation". Mark location for each wheel and hub/drum. They will be reinstalled on the same spindle.
- ② Check suspension for wear and proper fastener torque. (See page 32-33.)
- ③ Install a fully charged break-away battery.
- ④ Follow all hub/drum and brake service procedures. Replace or repair any worn or damaged parts. **Be sure to remove and check bearings.** (See pages 21-22.)
- ⑤ Reinstall hub/drums and wheels in same position as removed.

 **FASTENER TORQUE WARNING** *Wheel nut torque must be checked with a torque wrench and adjusted if necessary. Do not overtighten. Be sure to follow the instructions on page 26.*



Service Preparation

The service and maintenance procedures are provided for use by qualified service technicians. Do not attempt to service, repair or work on brakes or axles unless you have appropriate mechanical knowledge and skills. You must understand all procedures and instructions before you begin to work on a unit. Some procedures require the use of special tools for safe and correct service. Failure to use special tools when required can cause damage to equipment and components. Lack of proper training, failure to follow proper procedures, or not using proper tools or safety equipment, can result in property damage, serious personal injury, or loss of life.

Lifting Trailer

Many service and maintenance procedures require the trailer to be elevated. Follow the trailer manufacturer's recommendations for lifting the trailer.

 **WARNING** *Do not work under a vehicle supported only by jacks or jack stands. Use additional auxiliary blocking. Jacks or jack stands could fail resulting in property damage, serious personal injury, or loss of life.*

- ① Lift the trailer until wheel rotates freely and secure trailer with appropriate jacks and auxiliary blocking. **Never use the axle or any portion of the suspension to lift or support the trailer. This will damage the axle and lead to premature failure.**
- ② If service requires the hub/drum or hub/rotor to be removed, remove the wheel and follow steps 3-5. **Refer to the schematic on page 24.**

 **ASBESTOS FIBER WARNING** ③ Remove the hub/drum or hub/rotor assembly by removing the grease or oil cap, cotter pin, castle nut, spindle washer (where required) and outer bearing. If a bearing drops it may be damaged and should be replaced. Pull the drum straight off the spindle being careful not to damage the spindle, bearings or races. The inner bearing and seal may stick to the spindle. If so, use a bearing puller to remove inner bearing.

- ④ Pry the seal with a seal removing tool or screwdriver. Do not drive seal out by hitting, punching, or tapping the inner bearing.
- ⑤ Wash bearings and races with solvent. Do not use water or steam as they may damage components or cause components to come loose. Apply a thin layer of grease or oil until ready to repack.

Replacing Complete Drum Brake Assembly (Electric & Hydraulic)

 **WARNING** *Improper brake adjustment can result in reduced brake performance or loss of brakes. Reduced brake performance can lead to property damage, serious personal injury, or loss of life.*

- ① Follow "Service Preparation" instructions on page 12.
- ② Remove fasteners which attach the brake backing plate to the brake flange. See schematics on pages 34-39.
- ③ Install new brakes. Be sure to use the proper side and install the brake with the magnet on the bottom or wheel cylinder at the top. When replacing a Hayes Brake with an AL-KO Brake, discard the old two piece dust cover. Reinstall fasteners and torque per page 25.
- ④ Reinstall hub/drum per instructions on page 24.
- ⑤ Follow instructions on page 26 for "Completing Service".

K80 Electric Brake: K80 brakes are not self adjusting. Follow service schedule on page 8.

- ① Lift trailer as outlined on page 12 "Service Preparation". **Do not remove the wheels or hub/drum assembly.**
- ② Locate the adjusting slot and, while spinning the wheel, use a standard brake adjusting tool or the blade of a screwdriver to rotate the star wheel until there is a heavy brake drag.
- ③ Loosen until the wheel turns freely about 3/4 to one full turn.
- ④ Replace the protective plug to keep dirt and moisture out.
- ⑤ Replace all parts and lower trailer as outlined on page 26 "Completing Service".
- ⑥ Repeat procedure for other wheels. Never adjust just one brake. It is recommended that all brakes on the trailer, or at least both brakes of one axle, be adjusted at the same time.

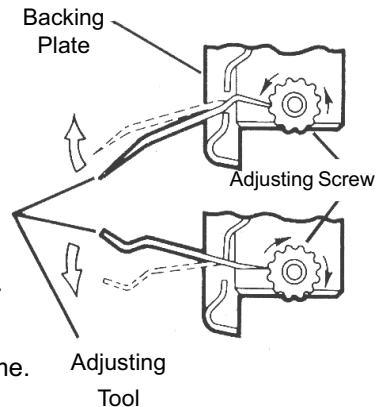



Brake Adjustment Cont.

8K-16K Electric Drum Brake

The 12" x 3-3/8", 12-1/4" x 3-1/2" and 12-1/4" x 5" electric brakes are self adjusting during hard reverse stops. When the leading shoe leaves the anchor pin, the adjuster cable pulls the adjuster pawl upward to engage the next tooth of the adjuster star wheel if adjustment is necessary due to normal wear. To release the shoes, the adjuster pawl must be pulled away before the star wheel can be turned backward to decrease brake adjustment.

Upon reinstallation, the shoes should be adjusted to the point of lightly dragging the drum and approximately .010" clearance on the shoe with the most shoe to drum clearance measured at the 3 or 9 o'clock position.

8K-12K Hydraulic Drum Brake

The 12" x 3-3/8" and 12-1/4" x 3-1/2" hydraulic drum brakes are self adjusting during stops. The first application of the brakes during bleeding will expand the shoes to the drum diameter and the self-adjuster will hold them with proper clearance.

To release the shoes, reach through the backing plate with a brake adjuster or large screwdriver and lift the ratchet lever allowing the shoes to collapse, thus allowing easy removal of the hub and drum.

10K-12K Hydraulic Disc Brake

The hydraulic disc is self adjusting. To remove the hub and rotor, the caliper assembly must be removed from the torque plate by removing two 3/8" bolts and the retainer plates.

10K-16K Air Drum Brakes

Slack adjusters should be adjusted to keep push rod travel to a minimum without the brakes dragging.



**FASTENER TORQUE
WARNING**

Improper brake nut torque can cause the backing plate to become detached from the brake flange causing brake failure. Reduced brake performance can lead to property damage, serious personal injury or loss of life.





Inspecting & Replacing Brake Linings

To prevent serious eye injury, always wear safety eye protection when you perform vehicle maintenance or service.

DANGER

**SAFETY GLASSES
REQUIRED**

 **ASBESTOS FIBER
WARNING** *Current AL-KO brake linings are asbestos free. Other brake linings may contain asbestos fibers, a cancer and lung disease hazard. Many brake linings contain non-asbestos fibers, whose long-term effects to health are unknown. You must use caution when you handle both asbestos and non-asbestos materials. (See page 45.)*



Follow “Service Preparation” procedures on page 12. With the trailer lifted and the hub/drum removed, inspect the linings for wear or contamination from oil or grease. Hairline heat fissures are not uncommon in bonded shoes and pose no cause for concern. If there are any questions concerning the severity of cracking, consult with an expert. If the lining is worn to 1/16" or less on bonded and 1/32" or less on riveted linings, or shows irregular wear or contamination from foreign substances, the shoes should be replaced with original AL-KO parts.



 **WARNING** *Brake shoes should always be replaced in pairs, both brakes on the same axle. Failure to replace in pairs can result in reduced brake performance or loss of brakes which could result in property damage, serious personal injury, or loss of life.*





Replacing Brake Linings (Electric and Hydraulic Drum Brakes)

8K-12K Electric and Lining Replacement Procedures

- ① Remove hub/drum assembly. Clean and inspect hub/drum assembly, bearings, seal and spindle.
- ② Clean brake assembly with a non-residual brake cleaner.
- ③ Inspect magnet and lever assembly for damage and/or abnormal or excessive wear.
- ④ Secure magnet assembly to lever arm with a heavy rubber band or thread.
- ⑤ For ease of installation, disconnect magnet lead wires from power source and remove brake assembly from axle beam.
- ⑥ Remove magnet, lever assembly and slipper block from brake assembly.
- ⑦ To remove old shoe and linings, remove the hold down bolts, washers, nuts, and cotter pins.
- ⑧ Remove bias lever and adjuster lever from old shoe and linings. Install on new shoe and linings.
- ⑨ Clean and properly lubricate backing plate and adjuster assembly with Lubriplate, block grease or equivalent.
- ⑩ Install new shoe and linings.
- ⑪ Install slipper block, magnet and lever assembly.

8K-12K Hydraulic Shoe and Lining Replacement Procedures

- ① Remove hub/drum assembly. Clean and inspect hub/drum assembly, bearings, seal and spindle.
- ② Clean brake assembly with a non-residual brake cleaner.
- ③ Remove self-adjuster assembly and springs.
- ④ To remove old shoe and linings, remove the hold down bolts, washers, nuts, and cotter pins.
- ⑤ Clean and properly lubricate backing plate and adjuster assembly with Lubriplate, block grease or equivalent.
- ⑥ Install new shoe and lining assemblies. Make sure cylinder push rods are properly located on shoe web.
- ⑦ Install self-adjuster assembly and springs.
- ⑧ Collapse self-adjuster assembly enough to get the hub and drum installed.



Replacing Brake Linings (Electric and Hydraulic Drum Brakes)

10K-12K Disc Pads Replacement Procedures

- ① Release brake line pressure by opening the bleeder screw.
- ② Using large C-clamp, retract pistons into caliper.
- ③ Remove retainer plates, upper and lower.
- ④ Lift caliper from torque plate being careful not to kink brake hose.
- ⑤ Inspect rotor for wear and repair or replace if needed.
- ⑥ Lift worn brake pad from torque plate and install new one.
- ⑦ Replace outer pad on caliper housing.
- ⑧ Reinstall caliper on rotor.
- ⑨ Torque caliper retainer clips to 18ft. lbs. of torque.
- ⑩ Bleed system. (Follow actuation system instructions for bleeding all hydraulic brakes.)

8K-12K Hydraulic Wheel Cylinder Replacement Procedures

- ① Remove drum.
- ② Clean brake assembly with a non-residual brake cleaner.
- ③ To remove shoes from backing plate you must:
 - a. Remove self-adjuster
 - b. Remove retract springs (upper & lower)
 - c. Remove hold down bolts, washers, nuts, and cotter pins.
- ④ Disconnect hydraulic line from cylinder.
- ⑤ Inspect new wheel cylinder and parts to ensure hydraulic lines will connect.
- ⑥ Install new wheel cylinder in reverse order.
- ⑦ Install drum.
- ⑧ Ensure proper operation, bleeding hydraulic system if necessary.
- ⑨ Bleed system. (Follow actuation system instructions for bleeding all hydraulic brakes.)



WARNING

Use only genuine AL-KO replacement parts. Other shoes may "fit" but not function properly.

Installation of non-AL-KO parts could result in reduced brake performance or loss of brakes. Reduced brake performance can lead to property damage, serious personal injury, or loss of life.



FASTENER TORQUE WARNING

Torque wheel nuts after reinstalling wheel and then every fifty miles for the following 200 miles. Over or under torqued wheel nuts can cause the wheel to separate from the wheel mounting

surface during operation. (See page 26 for specifications.) Wheel separation can lead to property damage, serious personal injury, or loss of life.



Inspecting & Replacing Brake Magnets

- ① Follow the procedures on page 12 for “Service Preparation”.
- ② The magnet assembly can be inspected for wear while it is still assembled to the brake. Lay a straight edge over the length of the magnet face and check for flatness.

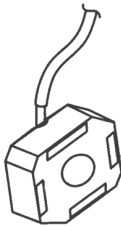
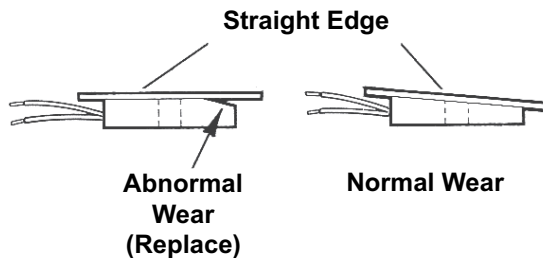

- ③ All AL-KO electric brakes use magnets that are similar in design. Properly functioning magnets that show normal wear may be used until copper coil is visible through the friction material in the center of the magnet.

- ④ If magnet shows abnormal wear, inspect the brake drum armature surface. The armature plate may also need to be replaced.
- ⑤ If you suspect that the magnet is not functioning properly and it shows no sign of abnormal or excessive wear, check for a short circuit. Remove the magnet from the brake as follows:
 - ✓ Disconnect the magnet leads from the trailer’s wiring harness and remove the strain relief to allow the magnet leads to be pulled through the backing plate.
 - ✓ Remove clips holding magnet leads to the lever arm or return spring.
 - ✓ Remove clips holding magnet to lever arm and remove magnet. Keep the clips and magnet spring. Follow procedures on page 19.

Magnet Electrical Evaluation

Coil to Housing Short Circuit Test

- ① Connect one end of an ammeter (the ammeter must have a minimum scale of 5 amps) to either of the magnet wires. This test requires only one of the magnet leads.
- ② Connect the other end of the ammeter lead to the positive battery post.
- ③ Connect a separate piece of 16 gauge wire from the negative battery post to the magnet housing.
- ④ If the amperage registers current, a short is indicated and the magnet must be replaced per instructions on page 20.

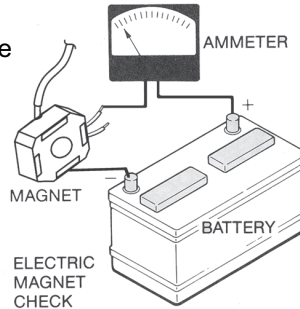

Note: The magnets must be checked as soon as power is connected. The amperage readings will drop as the temperature increases.

Coil Short Circuit Test

- ① Connect one magnet wire to one of the ammeter leads.
- ② Connect the other magnet wire to the negative battery post.
- ③ Connect remaining ammeter lead to positive battery post.
- ④ If the amperage reading at 12 volts is greater than 3.2 amps, the magnet should be replaced per instructions on page 20.
- ⑤ If the amperage reading is lower than 2.8 amps, check battery charge.

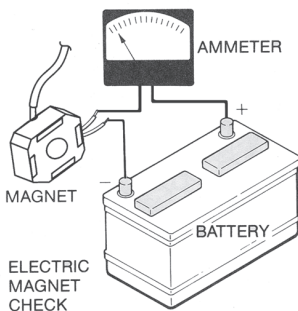

Note: The magnets must be checked as soon as power is connected. The amperage readings will drop as the temperature increases.



WARNING *Improper magnet function can result in reduced brake performance or loss of brakes. Reduced brake performance can lead to property damage, serious personal injury, or loss of life.*

8K-12K Magnet Replacement Procedures

To prevent serious eye injury, always wear safety eye protection when you perform vehicle maintenance or service.

DANGER
SAFETY GLASSES
REQUIRED

- ① Remove Hub/Drum assembly, clean and inspect Hub/Drum assembly, bearings, seals and spindle.
- ② Clean brake assembly with a non-residual brake cleaner.
- ③ Disconnect magnet lead wires from terminals on dust cover.
- ④ Remove strain relief and adapter from backing plate.
- ⑤ Pull lead wires through backing plate hole.
- ⑥ Remove wire retaining rings holding magnet lead wires to lever arm. Remove magnet.
- ⑦ Install new magnet assembly to lever arm, securing magnet body to lever arm with a heavy rubber-band or thread. (First heavy braking will roll off or break rubber-band or thread)
- ⑧ Reinstall magnet lead wires to lever arm using wire retaining rings.
- ⑨ Reinstall strain relief and adapter into backing plate connecting lead wires to dust cover terminals.
- ⑩ Reinstall drum.

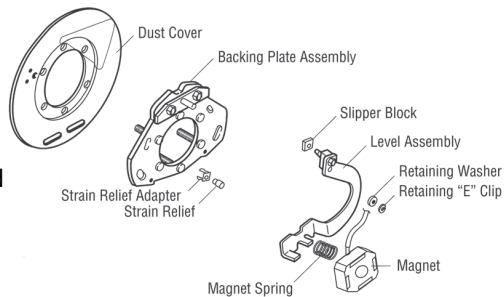

⚠ WARNING *Road test before using. Be sure area is clear of traffic and pedestrians. Do not exceed 30 m.p.h. Follow procedures outlined by the controller manufacturer. Failure to do so could result in property damage, serious personal injury, or loss of life.*

**** Some brakes do not use wire clips. Route magnet wire with loom retaining ring, as previously installed.**



Inspecting Bearings Races & Seals

Most trailer axle bearings require periodic maintenance (see pages 8-9) to ensure reliable, safe operation of your trailer.

- ① Follow the procedures outlined on page 12 for “Service Preparation.” Refer to the schematic on pages 35-44.
- ② Wash the bearings and races with solvent cleaner to remove all old grease or oil. Do not use compressed air or steam. They may damage components or cause components to come loose.
- ③ Check the bearings and races for worn, scored, damaged, grooved, indented, etched, spalled, gouged, nicked, corroded or otherwise damaged parts.
- ④ Check seal for nicks, tears or wear.
- ⑤ Replace damaged seals, bearings or races (see page 22). Always replace bearings and races in matched sets.



FASTENER TORQUE *Improperly torqued spindle nuts can*
WARNING *cause the hub/drum & wheel to separate*
from the axle resulting in property
damage, serious personal injury, or loss of life.





Installing Bearings Races & Seals

To prevent serious eye injury, always wear safety eye protection when you perform vehicle maintenance or service.

DANGER

**SAFETY GLASSES
REQUIRED**

Follow the procedures outlined on page 12 for "Service Preparation."

Install Races

Always replace bearings and races as a set. Install races (*new hub/drums should have races already installed*) using a mild steel drift or bar. Do not use hardened steel or brass bars as they may damage, chip or leave deposits on the races. Final setting of the race against the shoulder should be checked with feeler gauges and be within 0.002" of the shoulder in the hub/drum.

Pack Bearings (Grease Lubrication Only)

Prior to repacking bearings, all grease must be removed from the hub/drum and bearings. Bearings should be packed by machine or by hand methods to insure that grease is forced into the cavities between the rollers, cone and cage of the bearings. For axles equipped with oil, fill hub with oil after assembly.

Grease

Use a high temperature, automotive type wheel bearing grease produced by a reputable manufacturer. The soap type should be lithium complex or equivalent. Use NLGI Grade 2 product with a minimum dropping point of 440° F.

Oil: Use a high grade, SAE 90 gear oil.

Installing Seals

It is recommended to install a new seal after removing the hub/drum/rotor. For ease of removal and installation, remove the armature plate (for electric brakes) by removing the six flat head screws. Be sure that the inner race and fully packed (for grease only) inner bearing are installed. Apply a thin layer of permatex (or similar) sealant to the outside diameter of oil seal. Install the seal using the correct size seal driver. If this is not available, use a clean block of wood which is large enough to cover the entire seal. Tap block to seat seal. Reinstall armature plate if required.



WARNING

Improper seal or bearing installation or adjustment, or insufficient maintenance, can lead to wheel bearing failure which could cause the hub/drum and wheel to separate from the axle during operation resulting in property damage, serious personal injury, or loss of life.



Brake Drum/Rotor

Inspecting the Brake Drum

Follow the procedures outlined on page 12 for “Service Preparation”.

Check the armature surface (electric braked axles only) for excessive galling due to severe contamination (mud, stones, etc.). One or two light score marks are not cause for replacing the armature. Under normal conditions, the armature surface should last indefinitely.

Inspect the drum or rotor's shoe surface. This surface should have a dull gray appearance and be free from heavy scoring and/or excessive wear. One or two light score marks are not cause for resurfacing or replacing the drum or rotor. If there are any questions concerning the condition of a part, consult an expert. Drums or rotors that are heavily scored or with 0.020" runout should be replaced or resurfaced. Do not exceed the maximum diameter cast in the brake drum. Replace drums worn to more than 12.39".



WARNING

Heavily scored, worn or oversized drums or rotors can result in reduced brake performance or loss of brakes. This could result in property damage, serious personal injury, or loss of life.

Resurfacing the Brake Drum

A standard drum lathe may be used to machine the shoe surface. Do not exceed the maximum diameter cast into the brake drum or the minimum thickness cast into the rotor. The drum should be replaced if it must be bored more than the maximum diameter cast in the brake drum.

Be sure to remove any metallic chips and contamination resulting from drum machining.



WARNING

Failure to remove chips could cause bearing failure which could cause the hub/drum and wheel to separate from the axle. This could result in property damage, serious personal injury, or loss of life.

Reinstall races per instructions on page 22. Replacement or new hub/drums should have races already installed.



Hub and drum (#99 & #120) Removal

- ① Use a 2-1/4" socket or large wrench to remove oil cap.
- ② Use a catch container for oil as cap is removed.
- ③ Remove wheels and tires.
- ④ Use pliers to remove cotter key from nut and spindle.
- ⑤ Using a 2-1/4" socket or large wrench remove spindle nut, washer and outer bearing from spindle.
- ⑥ Work drum from spindle (if you have a large puller) and attach to the drum studs, pushing against spindle end makes this task much easier removing hub/drum or rotor.

Note: When installing a new or resurfaced drum or rotor be sure to use new brake shoes or pads and new magnets (electric brakes).

DANGER
SAFETY GLASSES
REQUIRED

- ① For both grease and oil, apply a thin film of NLGI 2 grease (not oil) to spindle bearing journals to help protect them from fretting or corrosion.
- ② Install inner bearing and seal in hub/drums. (See page 22.) For grease applications, pack inner bearing before installation.
- ③ Slide hub/drum onto spindle, taking care not to damage spindle bearing or seal. Press until inner bearing stops against the inner bearing journal.

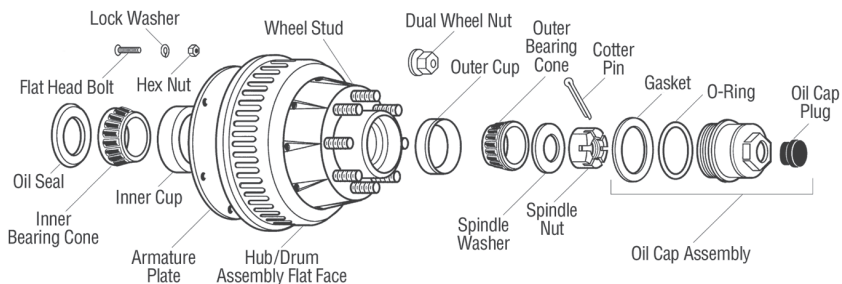

- ④ Install outer bearing. Pack outer bearings for grease applications.
- ⑤ Re-install washer when required (see pages 35, 40-44).
- ⑥ Follow bearing adjustment procedures on page 25.



Drum Replacement #120 Spindle Only

- ① Place hub & drum on a clean surface.
- ② Remove armature plate, if electric brakes, by removal of the six flat head screws.
- ③ Remove the (8) drum attachment bolts to separate drum from hub.
- ④ Install replacement drum on pilot.
- ⑤ Using a crisscross pattern tighten the (8) bolts until the drum is fully seated on the pilot.
- ⑥ Torque the (8) mounting bolts to 120 ft/lbs.
- ⑦ Remount the armature plate if required.

Bearing Adjustment

- ① To get the proper “feel” for bearing clearance, the spindle nut must turn freely on the spindle and the brake must be readjusted so that there is no drag on the drum.
- ② While slowly turning the hub/drum, tighten the spindle nut to approximately 20 ft/lbs then loosen. This is especially important if new bearing races have been installed.
- ③ With drum stationary (do not rotate), retighten the spindle nut to 7 ft/lbs (zero clearance) then back off one slot (0.001" - 0.010" end play) and align cotter pin hole. Insert cotter pin and bend both ends over end of spindle. Install grease cap or oil cap.
- ④ For oil applications fill wheel end with an approved gear oil to oil cap fill line. Note that oil must be given sufficient time to settle prior to final check of oil level.



WARNING

Improper bearing adjustment can lead to wheel bearing failure which could cause the hub/drum and wheel to separate from the axle during operation. This could result in property damage, serious personal injury, or loss of life.

Completing Service

- ① Be sure that all components have been properly installed.
- ② Adjust the brakes (pages 13-14). For new brakes, shoes, pads, rotors, drums, or magnets, follow break in procedure (pages 8-9).
- ③ Check brake function while trailer is still raised. Connect trailer to tow vehicle actuation system. The trailer brakes should activate and prevent the hub/drum/rotor from turning. Repeat for all brakes.
- ④ Install the wheels.

⚠ WARNING *When installing wheels other than those originally installed on the trailer, see the “Wheel Compatibility” warning on page 46. Installation of incorrect wheel could cause wheel separation which could result in property damage, serious personal injury, or loss of life.*

⚠ FASTENER TORQUE WARNING *It is important to maintain proper torque to provide safe and secure attachment of the wheel to the hub. Be sure to use wheel nuts that are compatible with the coin in the wheel. Improperly torqued wheel nuts can cause the wheel to separate from the wheel mounting surface during operation. This could result in property damage, serious personal injury, or loss of life.*

- ⑤ Start all lug nuts by hand to prevent cross threading.
- ⑥ Wheel nut torque requirements vary depending on the stud, size and manufacturer of the wheel.

Tighten wheel nuts by stages according to the following chart.

	STAGE 1	STAGE 2	STAGE 3
9/16 - 18 Cone Nut (8K)	25	50	100
5/8 - 18 Cone Nut (8K)	25	100	150
5/8 - 18 Cone Nut with Tension Ring	25	100	200
5/8 - Flanged Nut	25	100	300
5/8 - 18 Swiveling Flange Nut	25	100	275
3/4 - 16 Swiveling Flange Nut	25	100	375
3/4 - Dual Cap Nuts	25	100	500

- ⑦ Tighten each lug nut in the order shown to the torque shown in the chart.

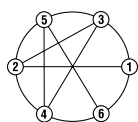

6 LUG BOLT PATTERN

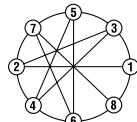

8 LUG BOLT PATTERN

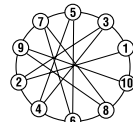

10 LUG BOLT PATTERN

- ⑧ Lower trailer and stow jacks, jack stands and auxiliary blocking.

⚠ WARNING *Road test before using. Be sure area is clear of traffic and pedestrians. Do not exceed 30 m.p.h. Follow procedures outlined by the controller manufacturer. Failure to do so could result in property damage, serious personal injury, or loss of life.*

Tire Inspection

⚠ WARNING *When replacing tires consult wheel and tire manufacturers' specifications for compatibility. Improperly matched wheels and tires may fail and cause property damage, serious personal injury, or loss of life. See "Wheel Compatibility" warning on page 46.*

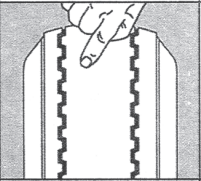
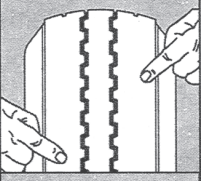
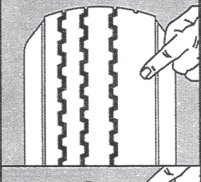
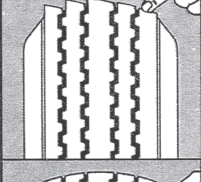
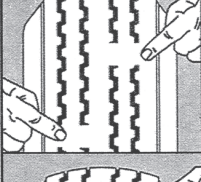
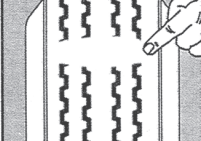
	Condition	Possible Cause	Remedy
	Even Center Wear	Over Inflation	Check & Adjust Pressure When Cold
	Inside & Outside Wear	Under Inflation	Check & Adjust Pressure When Cold
	Smooth, Side Wear - One Side	Loss of Camber or Overloading	Check & Unload As Necessary Have Alignment Checked
	"Feathering" Across The Face	Axle Not Square To Frame or Incorrect Toe In	Square Axles Have Alignment Checked
	Cupping	Loose Bearings or Wheel Balance	Check Bearing Adjustment and Wheel & Tire Balance
	Flat Spots	Wheel Lockup	Adjust Brakes



Troubleshooting (Electric and Hydraulic Brakes)

The most common reason for poor brake performance is improper brake adjustment. The first step in correcting brake problems is to adjust the brakes. (See pages 13-14.) This standard maintenance should be performed according to the schedule on pages 8-9.

The second most common problem is faulty, improperly installed or improperly used wiring, electrical components, hydraulic lines and actuation components. These components are not supplied or installed by AL-KO Kober but can greatly affect the performance of the brakes.

If **none of the brakes** are working, they probably have no power. If **all of the brakes** experience the same problem it is probably caused by an improper signal to the brakes. Possible causes include operator error, improper synchronization, faulty controller, break-away switch or actuator, and any wiring or plumbing problem. The first step in isolating brake problems is to identify the amount of power or pressure going to the brakes.

System voltage is measured at the magnets by connecting a volt meter to the magnet lead wires. Connect the trailer wire connector to the tow vehicle. The engine of the tow vehicle should be running. The voltage should start at 0 volts. As the controller bar is slowly actuated, it should **gradually** increase to about 12 volts. If the increase is not gradual the brakes would apply instantaneously. The lower the threshold voltage the smoother the brakes will apply.

System amperage is the amperage being drawn by all brakes on the trailer. Single magnet amperage can be measured with an ammeter attached at the magnet lead wires. Follow procedure above. Each magnet should draw about 3 amps at 12 volts. To check the total system the controller output to the brakes must be disconnected and the ammeter put into series in the circuit. With magnets cold (70° F), the ammeter should read about 3 amps for each brake or 12 amps for a tandem axle trailer (4 brakes). (Amperage is affected by the length and gauge of wire between ammeter and brake as well as between the power source and brakes.)

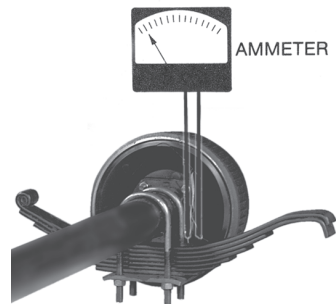

Use either alligator clips or volt/ohm meter probes.



Avoid working in wet conditions. Although you are not likely to get seriously shocked by 12 volt D.C. current, it can create a spark and ignite anything flammable.



Troubleshooting (Electric and Hydraulic Brakes)

Many brake problems result from faulty wiring, plumbing or a faulty component in the circuit. AL-KO Kober does not supply or install these components. For electrical or plumbing problem assistance contact the trailer manufacturer, dealer, or component (eg. brake controller) manufacturer.

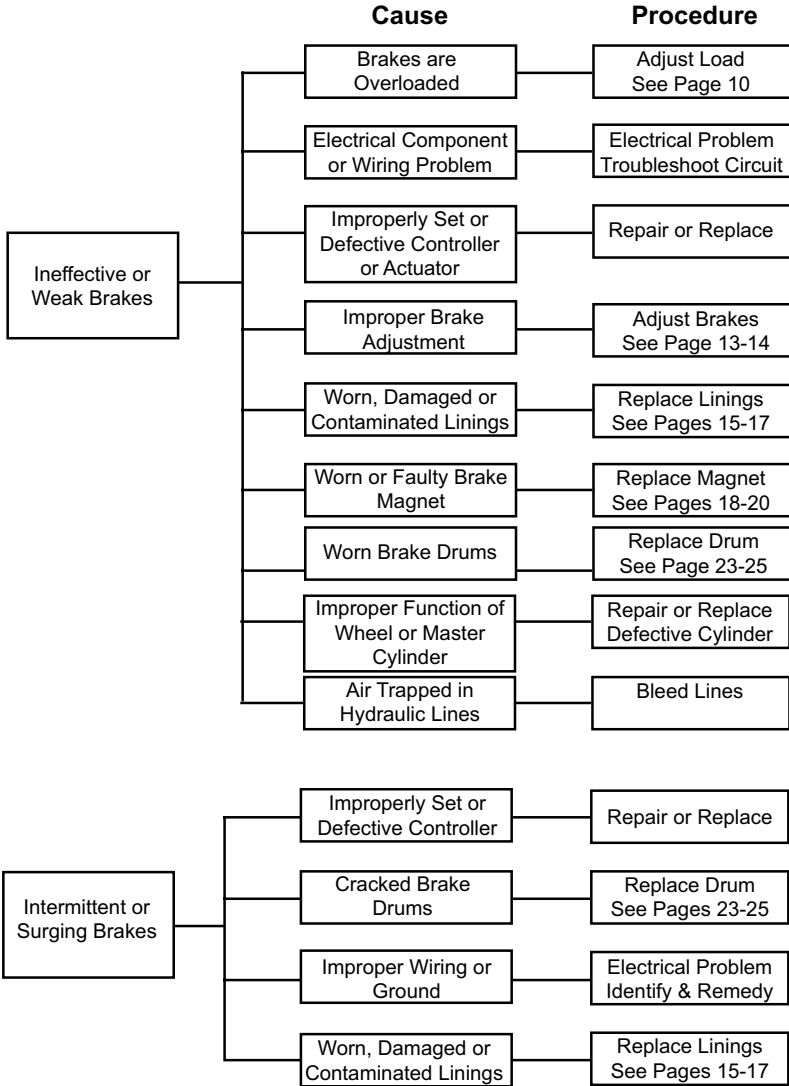



Troubleshooting

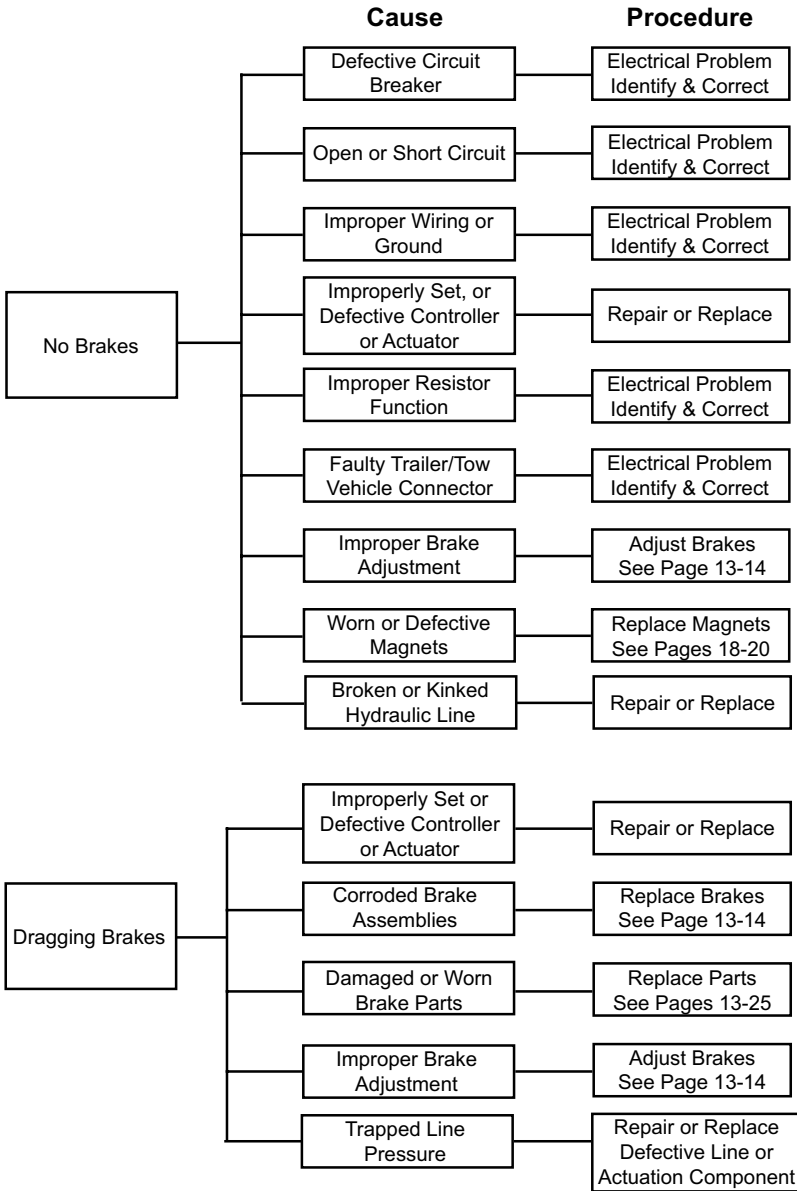

Troubleshooting

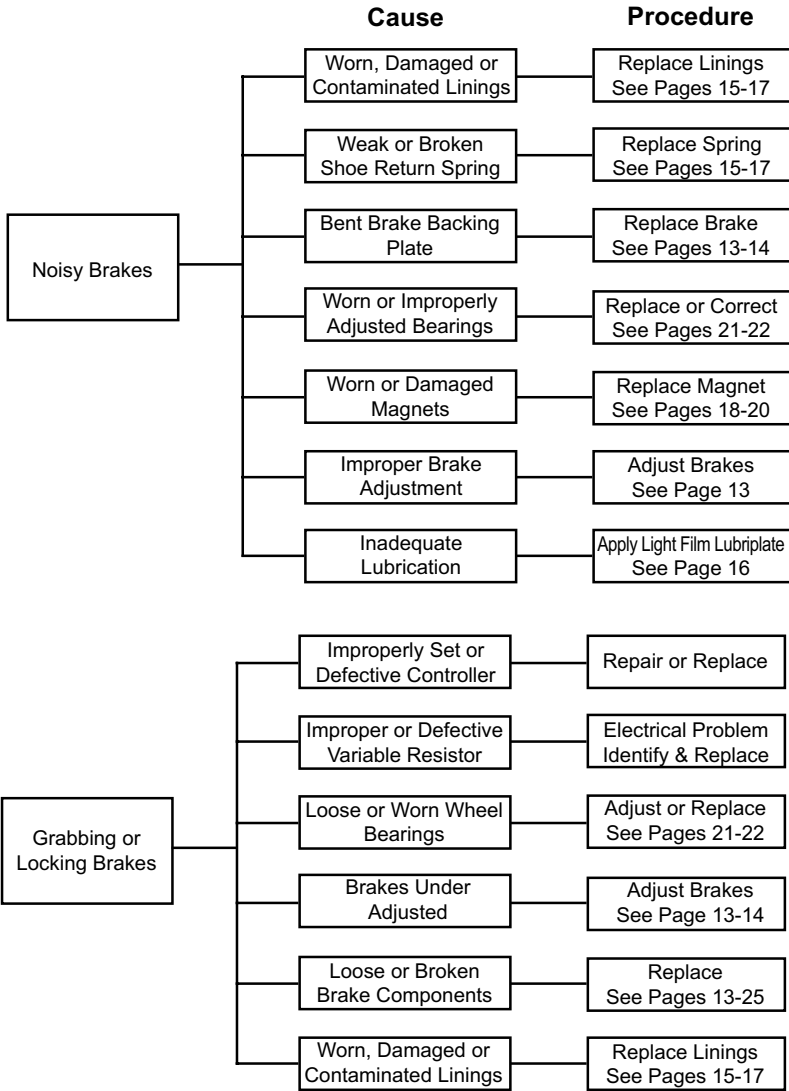



Leaf Spring Suspension

All suspension components should be visually inspected at least every 6,000 miles or 6 months. Check for loose fasteners and torque to proper values.



FASTENER TORQUE WARNING

Improper torque can cause component failure and the axles to become detached from the frame. This could result in property damage, serious personal injury, or loss of life.



WARNING See “Lifting Trailer” instructions on page 12. Failure to adhere to these instructions could result in property damage, serious personal injury, or loss of life.

Slipper Suspension

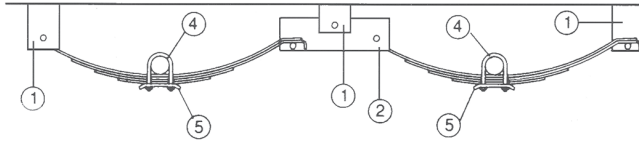

- ① Spring Hanger ② Equalizer ④ U-Bolt ⑤ Tie Plate

TORQUE VALUES		
Description	Torque (Ft. Lbs.)	
	MINIMUM	MAXIMUM
UB or B	120 Ft. Lbs.	
Spring Eye Bolt	225 Ft. Lbs	275 Ft. Lbs.
Equalizer	375 Ft. Lbs.	425 Ft. Lbs

- ① Follow the procedures outlined on page 12 for “Service Preparation”.
- ② Place suitable blocks under the axle beam. The blocks are only to support the axle weight once components are disconnected. Frame must be supported as outlined in “Service Preparation” on page 12.
- ③ Disassemble the U-Bolts, nuts and tie plates and rest the axle assembly on the blocks.
- ④ Replace axle, springs, spring eye bushings, equalizers and/or fasteners as required.
- ⑤ Reinstall repaired or replaced parts using proper torque values.
- ⑥ Although routine lubrication is not required, pivotal suspension points may be greased if desired.



Rubber Torsion Suspension

The AL-KO rubber suspension axle utilizes three rubber cords on each side of the axle assembly. They are encased under pressure between a hexagonal outer tube and a triangular inner tube. A trailing arm (*must be mounted as shown*) is welded to each inner tube. As the axle operates, the arm swings up and down, thus rolling the rubber. (Visit al-kousa.com for animation.)

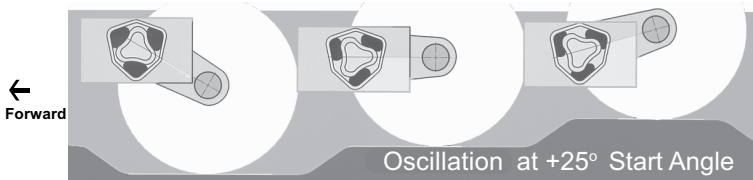

The position of the trailing arm varies depending on the starting angle. Three common start angles (+25°, 0°, and -20°) are shown below.

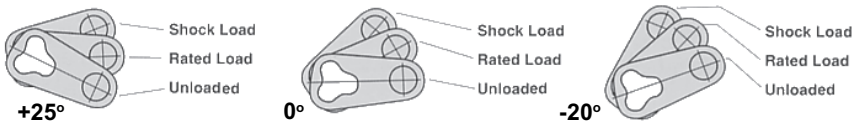

When used properly, the AL-KO rubber torsion suspension requires no maintenance and will provide years of reliable and uninterrupted service. (Abuse such as overloading or impact will greatly reduce axle life.) Brakes and hub/drum assemblies must be serviced according to the schedule on pages 8-9.

Some rubber torsion axles may be welded to the frame. Axles mounted with bolts should be checked at least every 6,000 miles or 6 months and the bolts torqued to proper values. Bolts may be located in the top or side of the axle mounting bracket (see below).

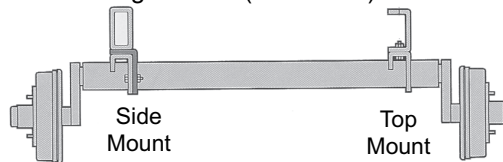

Description	Torque (Ft. Lbs.)	
	Minimum	Maximum
1/2" Bolt	110	120
5/8" Bolt	145	155



Use a torque wrench to set these values. Improper torque can cause component failure which could result in property damage, serious personal injury, or loss of life.



Electric Brake K-80 / 8K Axle

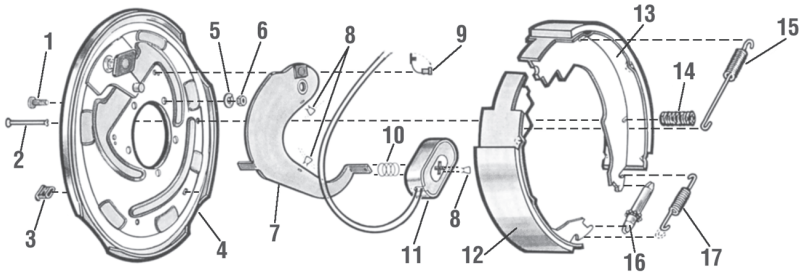

No.	Brake Part Description	AL-KO Part No.	Hayes Part No.
0	RH Brake Assembly Complete	568132	—
0	LH Brake Assembly Complete	568133	—
1	Brake Mounting Stud, 3/8" - 24	363989	090761
2	Shoe Hold Down Pin	568094	09661106
3	Plug Adjuster Slot	568089	096932
4	Backing Plate Assembly	—	—
5	Brake Lock Washer 3/8"	363334	363334
6	Brake Mounting Nut 3/8" - 24	363333	090625
7	RH Lever Assembly	568113	—
7	LH Lever Assembly (Shown)	568114	—
8	Clip, Wire & Magnet	568092	09680815
9	Strain Relief, Wire	568090	092715
10	Magnet Spring	568103	096522
11	Magnet Assembly	568111	568111
12	Primary Shoe & Lining	568150	—
13	Secondary Shoe & Lining	568151	—
14	Shoe Hold Down Spring	568093	10443
15	Shoe Retract Spring	568096	096527
16	Adjuster Screw Assembly	568110	60272401
16	Adjuster Screw Socket	568086	60272801
17	Adjuster Screw Spring	568095	096526

Hub & Drum Assembly K-80 / 8K Axle

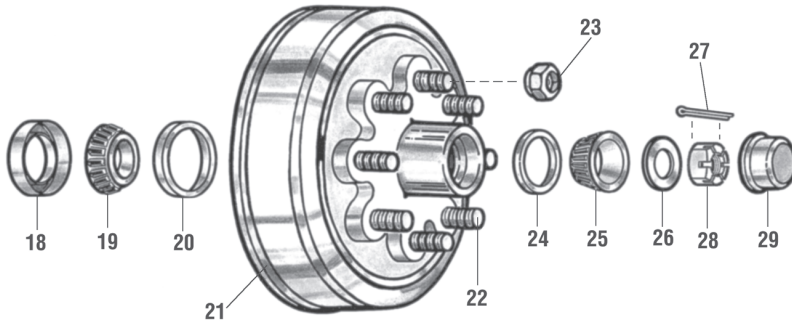

No.	Hub Part Description	AL-KO Part No.	Hayes Part No.
18	Grease Seal	568120	—
19	Inner Bearing Cone 28580	568125	093737
20	Inner Bearing Cup 28521	568152	093736
21	Hub & Drum w/Cups & Studs	—	—
21 A	8 on 6.5" Bolt Circle 9/16" Studs K80	568141	—
21 B	8 on 6.5" Bolt Circle 5/8" Studs K80	568142	—
22 A	Wheel Stud 9/16" - 18	363906	09251100
22 B	Wheel Stud 5/8" - 18	363910	090737
23 A	Wheel Nut 9/16" - 18 60° Cone	363895	090640
23 B	Wheel Nut 5/8" - 18 90° Cone	363698	090643
24	Outer Bearing Cup 25520	568153	093701
25	Outer Bearing Cone 25580	568130	093751
26	Spindle Washer 1 1/2"	568136	090525
27	Cotter Pin	568137	091903
28	Spindle Nut	568135	090623
29	Grease Cap	568124	—



Electric Brake

T-80, D-80, H-80 / 8K Axles

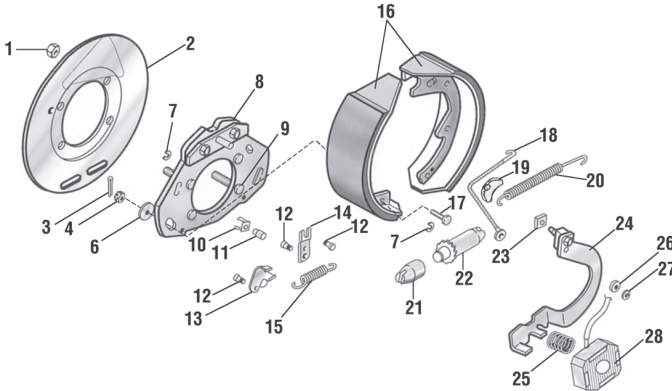

No.	Brake Part Description	AL-KO	Hayes Part No.
0	RH Brake Assembly complete (shown)	363602	60204306
0	LH Brake Assembly Complete	363601	60204406
1	Brake Attaching Nut, 1/2" - 20	568235	090617
2	Dust Cover	568289	09694612
3	Shoe Hold Down Cotter Pin	568224	091905
4	Shoe Hold Down Nut	568233	090647
6	Shoe Hold Down Washer	568232	090541
7	Pin Retaining "C" Clip	568249	096806
8	Backing Plate Assembly	—	—
9	Brake Mounting Stud 1/2" - 20	568250	09251523
10	Strain Relief Adapter	568258	096937
11	Strain Relief	568243	092715
12	Self Adjuster Pivot Pin	568238	096618
13	RH Auto Adjust Lever (shown)	568253	096321
13	LH Auto Adjust Lever	568254	096322
14	Self Adjuster Bias Lever	568241	096323
15	Self Adjuster Spring	568239	096523
16	Shoe and Lining Kit	K363924	K363924
17	Shoe Hold Down Bolt	568227	090759
18	Cable Assembly Self Adjuster	568245	096936
19	Cable Guide	568246	5758
20	Shoe Retract Spring	568226	5609
21	Self Adjuster Socket	568272	602723
22	RH Adjuster Assembly (shown)	568256	602717
22	LH Adjuster Assembly	568257	602718
23	Slipper Block	568242	096939
24	RH Lever Assembly (shown)	568236	603135
24	LH Lever Assembly	568237	603136
25	Magnet Spring	568240	096522
26	Lever Retaining Washer	568248	090540
27	Lever Retaining "E" Clip	568247	096803
28	Magnet	—	—
29	Magnet Assembly Kit contains #10,#11,#25,#28	K568252	K568252

Hydraulic Brake T-80, D-80, H-80 / 8K Axles

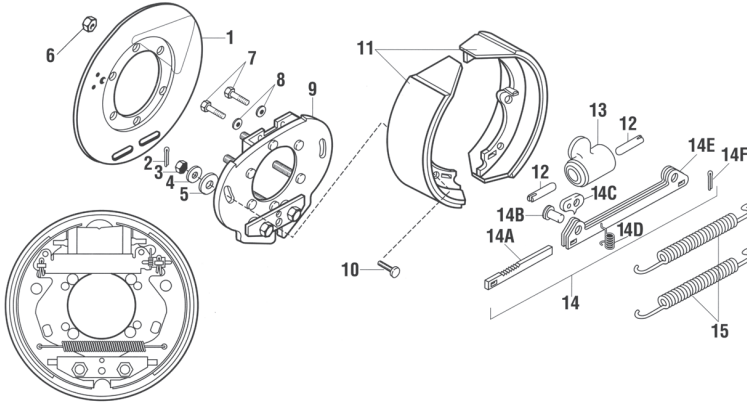

No.	Brake Part Description	AL-KO Part No.	Hayes Part No.
0	LH or RH Brake Assembly	568004	60206803
1	Dust Cover	568289.3	—
2	Shoe Hold Down Cotter Pin	—	09694612
3	Shoe Hold Down Nut	568224	09190501
4	Shoe Hold Down Belleville Washer	568233	090647
5	Shoe Hold Down Washer	568225	568225
6	Brake Attaching Nut 1/2" - 20	568232	090541
7	Bolt 3/8" - 16 x 3/4"	568235	090617
8	Lock Washer 3/8"	568231	090718
9	Backing Plate Assembly	363334	090532
10	Shoe Hold Down Bolt	—	—
11	Shoe & Lining Kit	568227	090759
12	Push Rod (Wheel Cylinder)	K363925	K363925
13	Cylinder-Wheel	568228	09550003
14	Self-Adjuster Assembly	568296	09550002
14 A	Rack	568259	60273001
14 B	Clevis Pin 3/8" x 3/4"	—	—
14 C	Pawl	—	—
14 D	Spring-Pawl	—	—
14 E	Sleeve Assembly	—	—
14 F	Cotter Pin 5/32" x 3/4"	—	—
15	Shoe Retract Spring	—	—
15	Shoe Retract Spring	568226	09652912
16	Connector-Brake Line, (not shown)	568230	09344501

Electric Brake 10K & 12K Axles

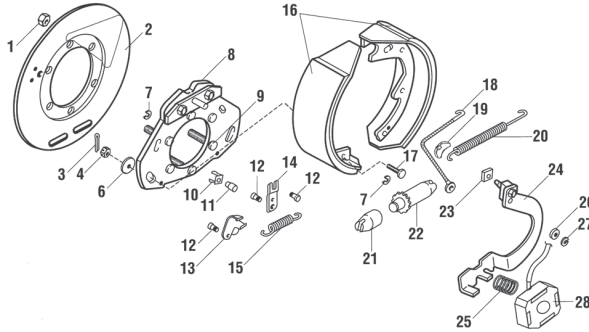

No.	Brake Part Description	AL-KO Part No.	Hayes Part No.
0	RH Brake Assembly Complete	568255.1	568255.1
0	LH Brake Assembly Complete	568255.2	568255.2
1	Brake Attaching Nut, 1/2" - 20	568235	090617
2	RH Dust Cover Assembly (AL-KO only)	568229.1	—
2	LH Dust Cover Assembly (AL-KO only)	568229.2	—
2 A	Upper RH Dust Cover (Hayes only)	—	09693402
2 B	Upper LH Dust Cover (Hayes only)	—	09693403
2 C	Lower 1/2 Dust Cover (Hayes only)	—	09693401
3	Shoe Hold Down Cotter Pin	568224	091905
4	Shoe Hold Down Nut	568233	090647
6	Shoe Hold Down Washer	568232	090541
7	Pin Retaining "C" Clip	568249	096806
8	Backing Plate Assembly	—	—
9	Brake Mounting Stud 1/2" - 20	568250	090755
10	Strain Relief Adapter	568258	096937
11	Strain Relief	568243	092715
12	Self Adjuster Pivot Pin	568238	096618
13	RH Auto Adjust Lever (shown)	568253	096321
13	LH Auto Adjust Lever	568254	096322
14	Self Adjuster Bias Lever	568241	096323
15	Self Adjuster Spring	568239	096523
16	Shoe & Lining Kit	K568251	K568251
17	Shoe Hold Down Bolt	568227	090759
18	Cable Assembly	568245	096936
19	Cable Guide	568246	5758
20	Shoe Retract Spring	568226	5609
21	Self Adjuster Socket	568272	602723
22	RH Adjuster Assembly (shown)	568256	602717
22	LH Adjuster Assembly	568257	602718
23	Slipper Block	568242	096939
24	RH Lever Assembly (shown)	568236	60313501
24	LH Lever Assembly	568237	60313601
25	Magnet Spring	568240	09652915
26	Lever Retaining Washer	568248	090540
27	Lever Retaining "E" Clip	568247	096803
28	Magnet	—	—
29	Magnet Assembly Kit contains #10,#11,#25,#28	K568252	K568252

Hydraulic Brake 10K & 12K Axles

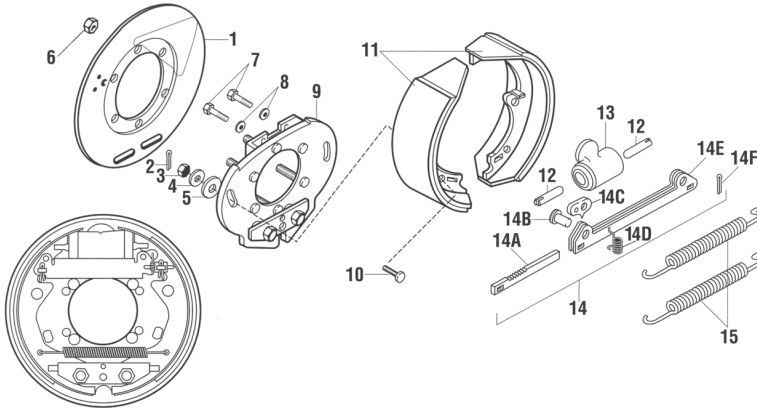

No.	Brake Part Description	AL-KO Part No.	Hayes Part No.
0	LH or RH Brake Assembly	568213	60206801
1	Dust Cover Assembly (AL-KO)	568229	—
1	Dust Cover Lower Half (Hayes only)	—	09693401
1	Dust Cover Upper Half (Hayes only)	—	09693404
2	Shoe Hold Down Cotter Pin	568224	09190501
3	Shoe Hold Down Nut	568233	090654
4	Shoe Hold Belleville Washer	568225	568225
5	Shoe Hold Down Washer	568232	090541
6	Brake Attaching Nut 1/2" - 20	568235	090617
7	Bolt 3/8" - 16 x 3/4"	568231	090718
8	Lock Washer 3/8"	363334	090532
9	Backing Plate Assembly	—	—
10	Shoe Hold Down Bolt	568227	090759
11	Shoe & Lining Kit	K568234	K568234
12	Push Rod	568228	09550003
13	Cylinder-Wheel	568214	09550001
14	Self-Adjuster Assembly	568259	60273001
14 A	Rack	—	—
14 B	Clevis Pin 3/8" x 3/4"	—	—
14 C	Pawl	—	—
14 D	SpringPawl	—	—
14 E	Sleeve Assembly	—	—
14 F	Cotter Pin 5/32" x 3/4"	—	—
15	Shoe Retract Spring	568226	09652912
16	Connector-Brake Line, Not Shown	568230	09344501

Hub & Drum Assembly

T-80, D-80, H-80 / 8K Axles

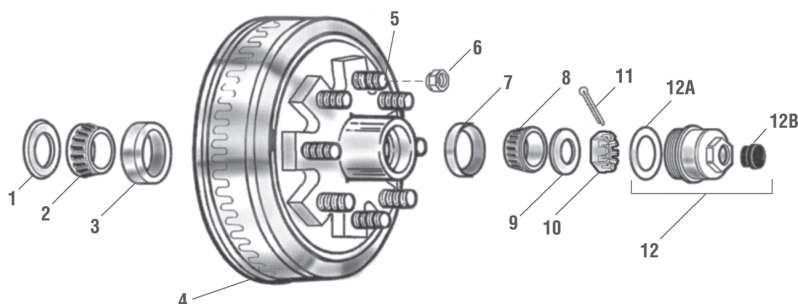

No.	Hub Part Description	AL-KO Part No.	Hayes Part No.
1	Oil Seal 370219BG (National)	568284	09103309
2	Inner Bearing Cone 25580	363196	093703
3	Inner Bearing Cup 25520	363911	093701
4	Hub & Drum 9/16" Stud 4.75 pilot	363694	09080644
4 A	Hub & Drum 5/8" Stud 4.75 pilot	363697	09080654
5	Wheel Stud 9/16" - 18	363906	09251100
5 A	Wheel Stud 5/8" - 18 x 2.75"	363910	09737
6	Wheel Nut 9/16" - 18 60° Cone	363895	090640
6 A	Wheel Nut 5/8" - 18 90° Cone	363698	090643
7	Outer Bearing Cup, 02420	363917	093744
8	Outer Bearing Cone, 02475	363604	093745
9	Spindle Washer	568326	090509
10	Spindle Nut	363257	09060101
11	Cotter Pin	363258	091901
12	Oil Cap Assembly	K363587	K363587
12	Oil Cap Assembly (Hayes prior to 1997)	K363587.1	K363587.1
12 A	Gasket, Oil Cap	568298	09103501
12 B	Oil Cap Plug	568223	092126

Hub & Drum Assembly General Duty 10K Axle

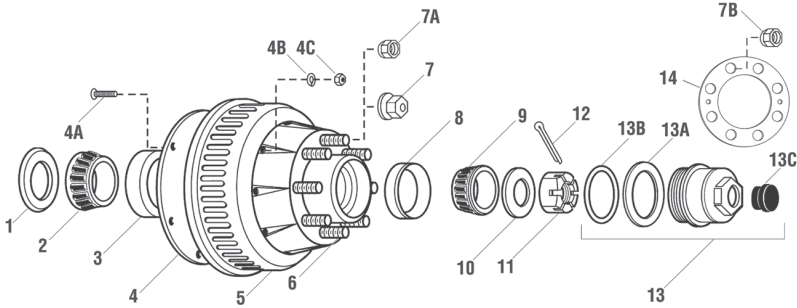

No.	Hub Part Description	AL-KO Part No.	Hayes Part No.
1	Oil Seal B370352BG (National)	568303	091030
2	Inner Bearing Cone, 28580	568125	093737
3	Inner Bearing Cup, 28521	568152	093736
◆ 4	Armature Plate	568261	092406
◆ 4 A	Flat Head Bolt, 1/4" – 20	568263	09070301
◆ 4 B	Lock Washer, 1/4"	568264	090502
◆ 4 C	Hex Nut, 1/4" – 20 Flat Face	568265	090610
◇ 5	Hub & Drum Flat Face 4.88 pilot	568270	09080572
* 5 A	Hub & Drum Coined 4.75 pilot	568704	09080567
◇*5 A	Hub & Drum (F.F.) 4.75 pilot for dual and/or single wheels	568353	09080587
◇*6	Wheel Stud, 5/8" x 2 3/4" for Single & Flat Face	363910	090737
◇*7	Dual Wheel Nut – Swiveling Flange 5/8" - 18	568216	09065602
* 7 A	Dual Wheel Nut – Fixed Flanged (Coined)	568703	090633
* 7 B	Single Wheel Nut 5/8" - 18 90° Cone	363698	090643
8	Outer Bearing Cup, 25520	568153	093701
9	Outer Bearing Cone, 25580	568130	093751
10	Spindle Washer	568136	090525
11	Spindle Nut	568135	090623
12	Cotter Pin	568137	091903
13	Oil Cap Assembly	K568220	K568220
13 A	Gasket	568297	09103502
13 B	O-Ring	568222	10693
13 C	Oil Cap Plug	568223	092126
14	Wheel Clamp Ring for 5/8" Studs	568348	—

◇ Used with Flat Face Wheels
* Used with Coined Wheel

◆ For Electric Brake Only
* Used with Single Wheel and/or Clamp Ring

Hub & Drum Assembly

Heavy Duty 10K & 12K Axle

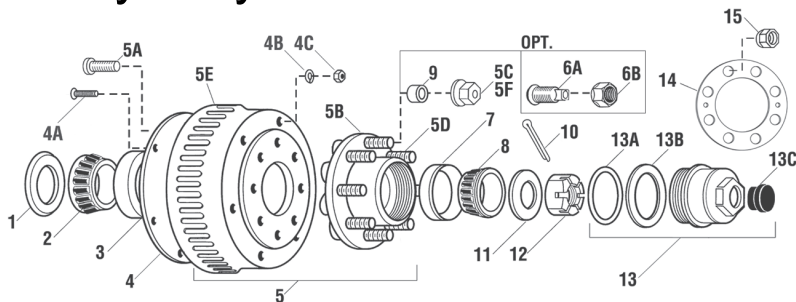

No.	Hub Part Description	AL-KO Part No.	Hayes Part No.
8 STUDS ON 6.50 DIAMETER (flat faced shown)			
1	Oil Seal B370014BG (National)	568217	091023
2	Inner Bearing Cone JM511946	568219	093717
3	Inner Bearing Cup JM 511910	568267	093716
4	Armature Plate	568261	092406
4	Armature Plate w/ Exciter Ring Air Brake	—	5106
4 A	Flat Head Bolt, 1/4" - 20	568263	09070301
4 B	Lock Washer, 1/4"	568264	090502
4 C	Hex Nut, 1/4" - 20	568265	090610
5	Hub & Drum (Flat Face) Elec/Hyd 5/8" Stud	568260	09089401
5	Hub & Drum (Coined) Elec/Hyd 5/8" Stud	—	090871
5	Hub & Drum (Flat Face) Air 5/8" Stud	—	09089411
5	Hub & Drum (Coined) Air 5/8" Stud	—	09080638
5	Hub & Drum (Flat Face) Elec/Hyd 3/4" Stud	—	09089408
5	Hub & Drum (Coined) Elec/Hyd 3/4" Stud	—	09080631
* 5	Hub & Drum (Flat Face) Air 3/4" Stud	—	09089415
** 5	Hub & Drum (Coined) Air 3/4" Stud	—	09080637
5 A	Hub & Drum Mounting Bolt	568262	090745
5 B	Hub Assembly (Flat Face) 5/8" Stud	568215	09089371
5 B	Hub Assembly (Coined) 5/8" Stud	—	090884
* 5 B	Hub Assembly (Flat Face) 3/4" Stud	—	09089372
** 5 B	Hub Assembly (Coined) 3/4" Stud	—	09080630
5 C	Dual Wheel Nut Swiveling Flange 5/8"	568216	09065602
5 C	Swiveling Flange Nut 3/4" (F.F.) 1-5/8" Flange	—	09065603
5 D	Wheel Stud 5/8" - 18 x 2.75"	363910	090737
5 D	Wheel Stud 3/4" - 16 x 3"	—	09077115
5 E	Drum Only (Air)	—	09090402
5 E	Drum Only Elec/Hyd Less Armature Plate	568699	090404
6 B	Flange Nut, 3/4" (Coined)	—	09065105
7	Outer Bearing Cup JM205110	568266	093714
8	Outer Bearing Cone JM205149	568218	093715
10	Cotter Pin	568137	091903
11	Spindle Washer 1 1/2"	568136	090525
12	Spindle Nut	568135	090623
13	Oil Cap Assembly	K568220	K568220
13 A	O-Ring	568222	10693
13 C	Plug	568223	092126
13 B	Gasket	568297	09103502



No.	Hub Part Description	AL-KO Part No.	Hayes Part No.
* 14	Wheel Clamp Ring for 5/8" Studs	568348	—
15	Wheel Nut 5/8" - 18 90° Cone	363698	—

6 STUDS ON 8.75 DIAMETER

5	Hub Drum Assembly (Air)	—	09080724
5 B	Hub	—	09080786
5 D	Stud 3/4" x 3 1/2"	—	09077116
5 F	Swiveling Flange Nut - 2" Flange	—	09065114
9	Wheel Stud Sleeve	—	09141905

HUB WITH DOUBLE CAP NUTS

5 B	RH Hub	—	09083510
5 B	LH Hub	—	09083511
5 D	Stud 3/4" RH	—	09077152
5 D	Stud 3/4" LH	—	09077153
6 A	Inner Cap Nut RH (Steel Wheels)	—	09065110
6 A	Inner Cap Nut LH (Steel Wheels)	—	09065111
6 B	Outer Cap Nut RH (Steel Wheels)	—	09065112
6 B	Outer Cap Nut LH (Steel Wheels)	—	09065113

10 STUDS ON 8.75 DIAMETER

5	Hub Drum Assembly (Air)	—	09080721
5 B	Hub	—	09080783
5 D	Stud 3/4"	—	09077116
5 F	Swiveling Flange Nut - 2" Flange	—	09065114
9	Wheel Stud Sleeve	—	09141905

HUB WITH DOUBLE CAP NUTS

5 B	RH Hub	—	09083530
5 B	LH Hub	—	09083531
5 D	Stud 3/4" RH	—	09077152
5 D	Stud 3/4" LH	—	09077153
6 A	Inner Cap Nut RH (Steel Wheels)	—	09065110
6 A	Inner Cap Nut LH (Steel Wheels)	—	09065111
6 B	Outer Cap Nut RH (Steel Wheels)	—	09065112
6 B	Outer Cap Nut LH (Steel Wheels)	—	09065113

*Used with flat face wheels

**Used with coin in-out wheels (replacement only)



Hub & Rotor Assembly 10K & 12K Disc Brake Axles

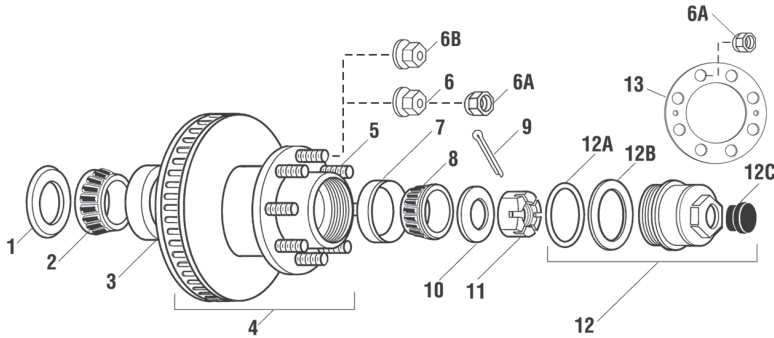

No.	Hub Part Description	AL-KO Part No.	Hayes Part No.
8 Studs on 6.50" Diameter			
1	Oil Seal B370014BG (National)	568217	091023
2	Inner Bearing Cone JM511946	568219	093717
3	Inner Bearing Cup JM511910	568267	093716
4	Hub & Rotor Flat Face 5/8"	09089421	09089421
4	Hub & Rotor Coined 5/8"	090814	090814
4	Hub & Rotor Flat Face 3/4"	09089425	09089425
4	Hub & Rotor Coined 3/4"	09080632	09080632
5	Wheel Stud 5/8" - 18	363910	090737
5 A	Wheel Stud 3/4" - 16 x 3"	—	09077115
* 6	5/8" Swiveling Flange Nut	568216	09065602
6 A	5/8" 90° Cone Wheel Nut	363698	090643
**6 B	5/8" Flanged Wheel Nut	—	090633
**6 B	3/4" Flanged Wheel Nut	—	09065105
* 6	3/4" Swiveling Flange Nut - 1 5/8" Flange	—	09065603
7	Outer Bearing Cup JM205110	568266	093714
8	Outer Bearing Cone JM205149	568218	093715
9	Cotter Pin	568137	091903
10	Spindle Washer 1 1/2"	568136	090525
11	Spindle Nut	568135	090623
12	Plastic Oil Cap Assembly	K568220	K568220
12 A	O-Ring	568222	10693
12 B	Gasket	568297	09103502
12 C	Rubber Plug	568223	092126
13	Wheel Clamp Ring for 5/8" Studs	568348	—

* Use with Flat Face Wheels

** Use with Coined Wheel



Asbestos and Non-Asbestos Fiber Warning



ASBESTOS FIBER WARNING

Contact OSHA for details concerning the dangers and proper handling of asbestos and non-asbestos fibers.

Contact OSHA for procedures to reduce exposure to asbestos fiber dust, a cancer and lung disease hazard. Because some brake linings contain asbestos, workers who service brakes must understand the potential hazards of asbestos and precautions for reducing risks. Exposure to airborne asbestos dust can cause serious and possibly fatal diseases, including asbestosis (a chronic lung disease) and cancer, principally lung cancer and mesothelioma (a cancer of the lining of the chest or abdominal cavities). Some studies show that the risk of lung cancer among persons who smoke and who are exposed to asbestos is much greater than the risk for non-smokers. Symptoms of these diseases may not become apparent for fifteen or more years after the first exposure to asbestos.

Workers must use caution to avoid creating and breathing dust when servicing brakes. **Specific recommended work practices for reducing exposure to asbestos should be obtained from OSHA.** Consult your employer's procedures for more details.

Following is a partial list of procedures that may apply.

Separate Work Areas. Whenever feasible, service brakes in a separate area away from other operations to reduce risks to unprotected persons.

Respiratory Protection. Wear a respirator equipped with a high-efficiency (HEPA) filter approved by NIOSH or MSHA for use with asbestos at all times when servicing brakes.

Compressed Air. Never use compressed air by itself, dry brushing, or a vacuum not equipped with HEPA filter when cleaning brake parts or assemblies.

Worker Clean-Up. After servicing brakes, wash your hands before you eat, drink or smoke. Shower after work. Do not wear work clothes home. Use a vacuum equipped with HEPA filter to vacuum work clothes after they are worn. Launder them separately. Do not shake or use compressed air to remove dust from work clothes.

Waste Disposal. Dispose of discarded linings, used rags, cloths and HEPA filters with care such as in clear plastic bags. Consult applicable EPA, state and local regulations on waste disposal.



Wheel Mounting & Compatibility



WARNING *Be sure to read and understand the following information before installing wheels. Installation of wheels which are not compatible with the axle assembly could result in wheel separation which can lead to property damage, serious personal injury, or loss of life.*

Unless otherwise specified, AL-KO Kober axles are built using our standard 4.88" diameter pilot for flat face wheels and swiveling flange nuts, which are supplied with the axles.

The following optional wheel pilots are available but must be specified at the time of order.

- ① **4.88" diameter, flat face hub for use with dual flat face wheels, a tension ring and 5/8" 90 degree wheel nuts.**
- ② **4.75" diameter, coined hub for use with dual, flat face wheels, a tension ring and 5/8" 90 degree wheel nuts.**
- ③ **4.75" diameter, coined hub for use with dual flat face wheels using swiveling flange nuts.**
- ④ **4.75" diameter, coined hub for use with single coined wheels using 5/8" 90 degree wheel nut.**
- ⑤ **4.75" diameter, coined hub for coined in and out wheels as used on older axles and using a flange cap nut.**



AL-KO Kober Corporation manufactures hubs and drums that are compatible with many wheels used in the trailer industry that have matching bolt patterns. AL-KO does not manufacture wheels, nor do they recommend a specific wheel for compatibility with the hubs and drums they manufacture. The wheel manufacturer should be contacted for proof of compatibility before use.



Customers using wheels which have not been tested for compatibility, must do so to insure they are compatible with AL-KO hubs and drums. Elements of compatibility include but are not limited to:

- ✓ Diameter of the hub mounting surface.
- ✓ Stud length and diameter.
- ✓ Location and number of studs.
- ✓ Center hole diameter for the wheel.
- ✓ Wheel mounting offset from the rim center.
- ✓ Rated capacity of the wheel.
- ✓ Wheel fastener torque.
- ✓ Wheel nut size and shape.
- ✓ Impact of the use of any wheel accessories (such as decorative center caps) that could affect the proper seating of the wheel to the hub surface.

A cornering fatigue test based on SAE J1095/SAE J267 and field tests are recommended for all wheels and rims to be installed on AL-KO hubs and drums. These tests require special expertise and equipment. Persons without such equipment or expertise should contact the wheel manufacturer to verify that a wheel is compatible with the AL-KO hubs and drums. AL-KO Kober Corporation is not responsible for wheels or rims that are installed on their hubs or drums.



Limited Warranty

AL-KO KOBER CORPORATION warrants to the original purchaser of its products that all workmanship and materials utilized in the construction of said parts by AL-KO KOBER CORPORATION will be free from substantial defects in material and workmanship for a period of one (1) year from the date of purchase of said product, with the following exception: In place of the one (1) year limited warranty, rubber suspension axles manufactured by AL-KO KOBER CORPORATION are warranted as provided herein for a period of five (5) years.

DISCLAIMER: THIS WARRANTY IS IN LIEU OF ALL OTHER WARRANTIES, EXPRESSED OR IMPLIED, INCLUDING BUT NOT LIMITED TO THE IMPLIED WARRANTIES OF MERCHANTABILITY AND FITNESS FOR A PARTICULAR PURPOSE, WHICH ARE EXPRESSLY DISCLAIMED. THERE ARE NO WARRANTIES THAT EXTEND BEYOND THE FACE HEREOF.

Exclusions: In addition thereto, the following items are specifically excluded from coverage by the terms of this Limited Warranty to wit: damage or defects which result from accident, collision, abuse, normal wear and tear, neglect, improper maintenance, improper installation, alignment, improper wheel nut torque, hub imbalance or any damage caused thereby, alteration, or overloading.

This warranty extends only to the original installation of AL-KO KOBER CORPORATION's products and is not transferable to any other parties. AL-KO KOBER CORPORATION does not assume responsibility for any promises, warranties, or representations beyond those expressed in this written document.

AL-KO KOBER CORPORATION's obligations and undertakings in this warranty are limited to the repair or replacement, at its option, of any defective products manufactured by AL-KO KOBER CORPORATION, and in no event shall AL-KO KOBER CORPORATION be liable for any consequential, indirect, or incidental costs or damages, including loss of use or any other damages of any type arising out of such defective parts or products.

Some states do not allow exclusion or limitation of incidental or consequential damages or implied warranties. In addition you may have other rights which vary from state to state. Any terms of this warranty which conflict with the laws of your state are deemed amended by the law of your state. In the event you believe any product manufactured by AL-KO KOBER CORPORATION has a defect or malfunction or failure to conform to this written warranty, you should contact AL-KO KOBER CORPORATION at one of its service location addresses:

21611 Protecta Dr.	301 N. Kennedy	4250 E. Lowell St.
Elkhart, IN 46516	Shawnee, OK 74801	Ontario, CA 91761-1529
(574) 294-6651	(405) 273-9315	(909) 390-7171

If you feel that a repair should be covered under warranty, be sure to contact AL-KO before having any warranty work performed.

In accordance with the following procedure:

1. Contact the closest service location.
2. A "Returned Merchandise Authorization" (RMA) number will be assigned to you.
3. Return the product to AL-KO KOBER CORPORATION at the service location chosen by you, freight prepaid. PLEASE RETURN ONLY THE DEFECTIVE PART OR PARTS AS DIRECTED WITH APPROPRIATE PRECAUTIONS AGAINST DAMAGE.
4. Supply the following information with the returned merchandise:
 - (a) Name, address, and telephone number of the original purchaser of the product and include the date of purchase
 - (b) Serial number and model or make of unit to which the axle is attached
 - (c) Serial number of the axle itself

AL-KO KOBER CORPORATION will replace or repair any defective products within a reasonable period of time and return them to you. If AL-KO KOBER CORPORATION determines there is no failure to conform to this Limited Warranty, you will be notified to retrieve your product from the service facility. AL-KO KOBER CORPORATION assumes no responsibility for merchandise not retrieved within thirty (30) days of notification to the original purchaser or owner of the product. This warranty has been drafted to comply with federal legislation and rules promulgated by the Federal Trade Commission. You may have additional legal rights in addition to those set forth in this written Limited Warranty.



Service Record

See An Authorized Dealer or Service Center

This section is designed to allow your dealer or qualified service technician to record that the recommended maintenance was completed at the appropriate mileage intervals. Be sure to ask your service provider to record the date and type of service performed.

	Service Center:	Work Order#:
Date:	Service Performed:	
Mileage:		

	Service Center:	Work Order#:
Date:	Service Performed:	
Mileage:		

	Service Center:	Work Order#:
Date:	Service Performed:	
Mileage:		

	Service Center:	Work Order#:
Date:	Service Performed:	
Mileage:		

	Service Center:	Work Order#:
Date:	Service Performed:	
Mileage:		

continued



Service Record

	Service Center:	Work Order#:
Date:	Service Performed:	
Mileage:		

	Service Center:	Work Order#:
Date:	Service Performed:	
Mileage:		

	Service Center:	Work Order#:
Date:	Service Performed:	
Mileage:		

	Service Center:	Work Order#:
Date:	Service Performed:	
Mileage:		

	Service Center:	Work Order#:
Date:	Service Performed:	
Mileage:		

	Service Center:	Work Order#:
Date:	Service Performed:	
Mileage:		

continued



Service Record

	Service Center:	Work Order#:
Date:	Service Performed:	
Mileage:		

	Service Center:	Work Order#:
Date:	Service Performed:	
Mileage:		

	Service Center:	Work Order#:
Date:	Service Performed:	
Mileage:		

	Service Center:	Work Order#:
Date:	Service Performed:	
Mileage:		

	Service Center:	Work Order#:
Date:	Service Performed:	
Mileage:		

	Service Center:	Work Order#:
Date:	Service Performed:	
Mileage:		

continued

Service Record

	Service Center:	Work Order#:
Date:	Service Performed:	
Mileage:		

	Service Center:	Work Order#:
Date:	Service Performed:	
Mileage:		

	Service Center:	Work Order#:
Date:	Service Performed:	
Mileage:		

	Service Center:	Work Order#:
Date:	Service Performed:	
Mileage:		

	Service Center:	Work Order#:
Date:	Service Performed:	
Mileage:		

	Service Center:	Work Order#:
Date:	Service Performed:	
Mileage:		

You're not alone with
AL-KO Kober.



AL-KO AL-KO Manufacturing Facilities

◆ AL-KO Distributors

★ Repair Facilities

Elkhart, IN
574-294-6651

Shawnee, OK
405-273-9315

Baldwyn, MS
662-365-5566

Ontario, CA
909-390-7171

www.al-kousa.com

Information contained in this publication was in effect at the time the publication was approved for printing and is subject to change without notice or liability.