

## Double Acting Power Unit Installations

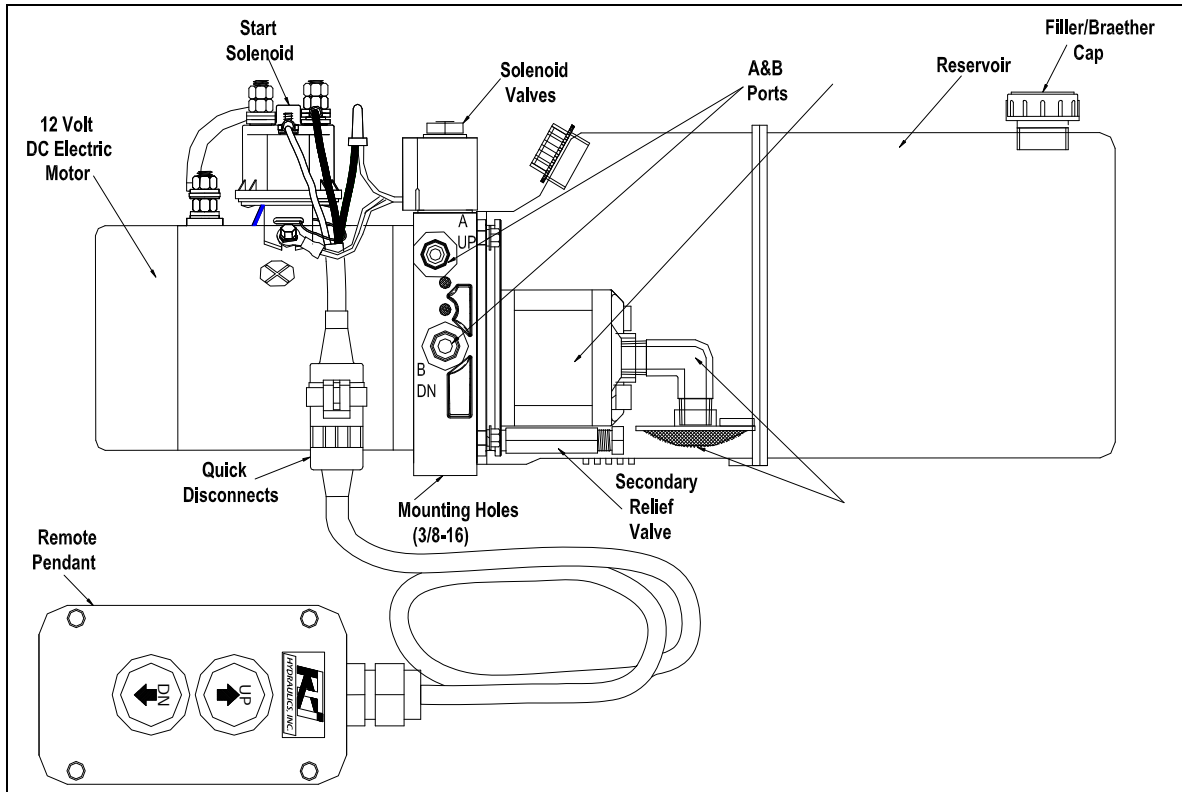

Diagram A-1

1. Install Fittings in A & B Ports (if necessary) Torque to 18 ft-lbs  
(Port's are #6 SAE female O-ring Boss)
2. Detach Remote Pendant From Power Unit
3. Mount Power Unit using 3/8-16 Mounting Bolts (see diagram A-4)
4. Remove Filler/Breather Cap to Fill Power Unit With Hydraulic Fluid (see fluid recommendations)
5. Connect Hydraulic Lines to Power Unit
  - a. Check Torque Specifications for Hose Fitting
  - b. Connect Base of Cylinder to A Port
  - c. Connect Rod End Of Cylinder to B Port
6. Connect Ground Wire to Vacant Start Solenoid Screw on DC Motor (see diagram A-4)  
(Minimum 4 Gauge Wire)
7. Connect Positive Cable From Battery to Start Solenoid (see diagram A-5)
  - a. Battery Cable Selection Guide to Insure Proper Wire Gage has Been Selected
  - b. Torque to 10 ft-lbs. (Over Tightening Studs on Start Solenoid Will Break Solenoid)
8. Connect Remote Pendant To Power Unit
9. Operate Power Unit While Also Keeping an Eye on Fluid Level In Reservoir
  - a. Insure Fluid Level Doesn't Go Lower Than ½ Way During Initial Start Up
  - b. When Cylinder is Fully Extended Insure Reservoir is ½ Full  
(The Reason for Not Filling the Reservoir Full is When Retracting the Cylinder the Rod End of the Cylinder Will Displace Fluid, Causing the Reservoir to Overflow)
10. Run the Cylinder Up and Down Until All the Air is out of the Hydraulic System
11. Fill Reservoir to Full line On Reservoir or Dipstick on Filler/Breather Cap

## Fluid Recommendations

KTI Recommends Using Top-Quality Hydraulic Fluids with ISO VG 22 – 68 (19.8 – 74.8 cSt, 97 – 347 SUS at 40°C) to Ensure Optimum Performance and System Life. Fluids Should have Anti-wear Properties, Rust and Oxidation Inhibitors. If Using Synthetic Fluids, Consult the Factory for Alternative Seal Material Requirements. **Do Not Use Biodegradable Hydraulic Fluid**

Fluid Temperature Range	ISO Viscosity Grade (ISO VG)
-5°F to + 140°F -21°C to + 60°C	22
+5°F to + 170°F -15°C to +77°C	32
+15°F to + 190°F -9°C to + 88°C	46
+30°F to +210°F -1°C to + 99°C	68

Do not operate Power Unit above recommended Fluid Temperature Range.

Premium hydraulic oil with proper ISO Viscosity Grade and additives such as Chevron EP, Mobile DTE 10, DTE 20 series, or Shell Tellus would be acceptable.

In Most Applications Use ATF Dextron III

## Battery Cable Selection Guide

When Selecting Battery Always Remember if you Increase the Distance From the Power Source You Need to Increase the Gauge of the Wire.

Never Mount a Power Unit More than 30 Feet from Power Source

<b>Amps</b>	<b>&lt; 5 Ft.</b>	<b>5-10 Ft.</b>	<b>10-15 Ft.</b>	<b>15-20 Ft.</b>	<b>20-25 Ft.</b>	<b>25-30 Ft.</b>
<b>100-150</b>	4 Gauge	2 Gauge	0 Gauge	02 Gauge	02 Gauge	03 Gauge
<b>150-190</b>	4 Gauge	1 Gauge	02 Gauge	03 Gauge	04 Gauge	04 Gauge
<b>190-250</b>	2 Gauge	0 Gauge	02 Gauge	04 Gauge	04 Gauge	04 Gauge
<b>250-300</b>	0 Gauge	02 Gauge	03 Gauge	04 Gauge	04 Gauge	04 Gauge

Diagram A-2

*If Improper Battery Cable is Selected Power Unit Will Exhibit low Battery Symptoms Which Include High Amp Draw.*

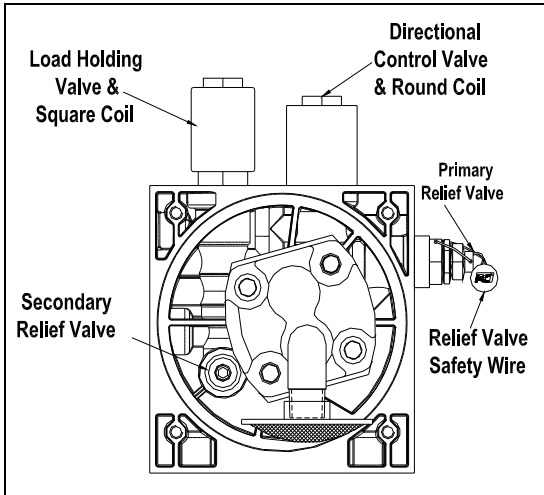

Diagram A-3

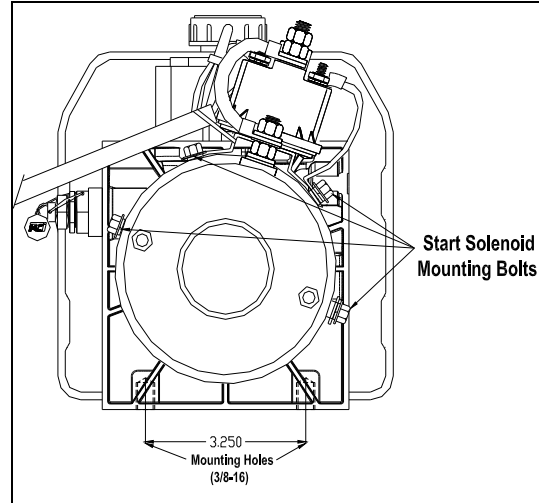

Diagram A-4

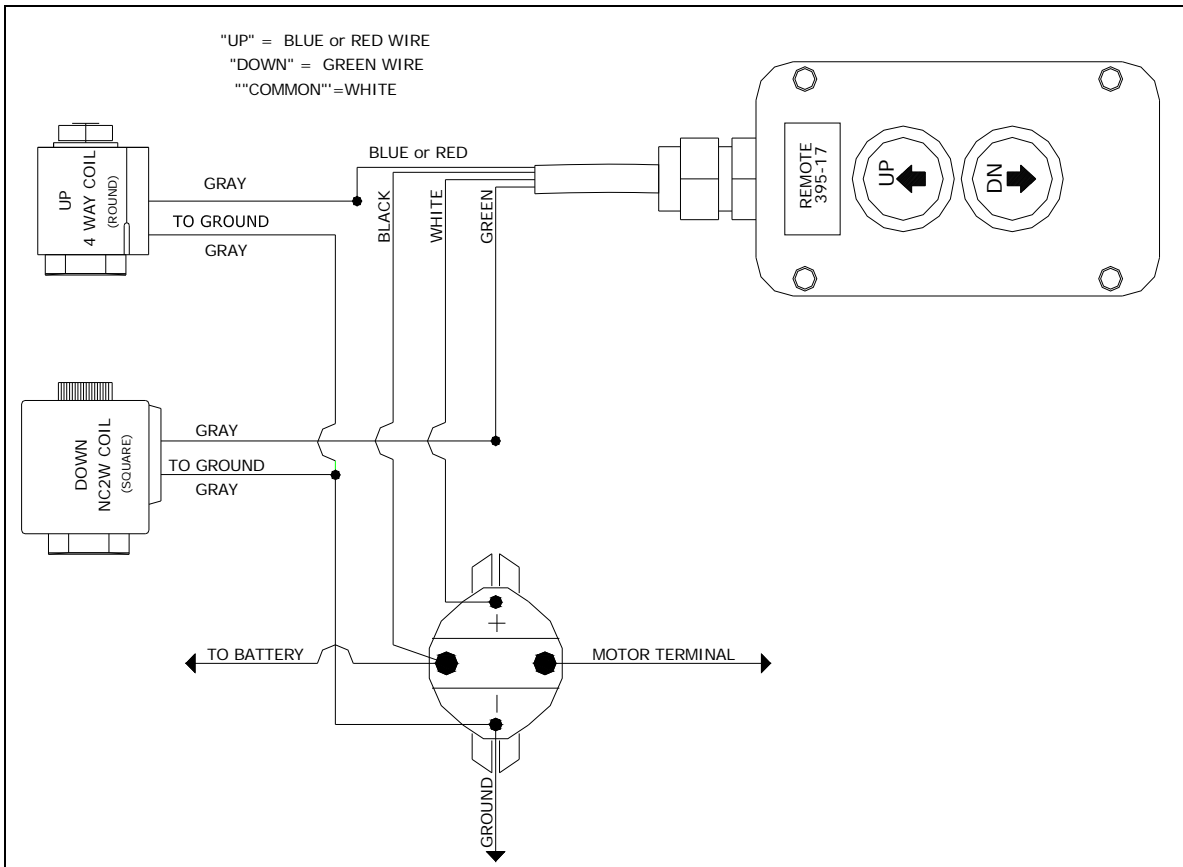

Diagram A-5

**Caution:** Cutting Safety Wire or Tampering with Relief Valve Will Void Warranty, And May Cause Injury or Even Death.